

TECHNICAL MANUAL

**OPERATOR'S, ORGANIZATIONAL, DIRECT
SUPPORT, AND GENERAL SUPPORT MAINTENANCE
MANUAL INCLUDING REPAIR PARTS LIST
FOR
SHAPER, METAL CUTTING
HORIZONTAL
NSN 3418-00-808-0475
(ROCKFORD MACHINE TOOL CO.)**

HEADQUARTERS, DEPARTMENT OF THE ARMY

JULY 1981

WARNING

Dirt or dirty oil in this machine will cause serious injury and expensive repairs. Use only clean vessels for handling oil, and pour all oil through strainer provided.

WARNING

Oil level must be maintained. Entire system should be drained and refilled with fresh oil often enough to maintain the lubricating value of the oil. All oils should have anti-rust and oxidation additives.

WARNING

Before breaking any circuit connections, be certain the electrical power is off and the system is relieved of trapped pressure.

Technical Manual }
No. 9-3418-201-14&P }

HEADQUARTERS
DEPARTMENT OF THE ARMY
Washington, DC, 17 July 1981

**OPERATOR, ORGANIZATIONAL, DIRECT SUPPORT
AND GENERAL SUPPORT MAINTENANCE MANUAL
INCLUDING REPAIR PARTS LIST
FOR
SHAPER, METAL CUTTING, HORIZONTAL
(NSN 3418-00-808-0475)**

REPORTING OF ERRORS

You can help improve this manual. If you find any mistakes or if you know of a way to improve the procedures, please let us know. Mail your letter, DA Form 2028 (Recommended Changes to Publications and Blank Forms), or DA Form 2028-2, located in the back of this manual direct to: Commander, US Army Armament Materiel Readiness Command, ATTN: DRSAR-MAS, Rock Island, IL 61299. A reply will be furnished direct to you.

Manufactured by: Rockford Machine Tool Co.
2500 Kishwaukee Street
Rockford, IL 61101

Procured under Contract No. DAAA09-76-C-6910

This technical manual is an authentication of the manufacturers' commercial literature and does not conform with the format and content specified in AR 310-3, Military Publications. This technical manual does, however, contain available information that is essential to the operation and maintenance of the equipment.

TABLE OF CONTENTS

	Page
Receiving and Handling.....	1
Cleaning	2
Installation	2
Floor Plan	3
Electrical Connections and Wiring.....	4
Hydraulic Oils	4
Wiring Diagram	5
Filling Oil Reservoir.....	6
Starting the Machine.....	6
Operating the Machine.....	8, 9
Universal Table.....	10
Power Feed.....	11
Cutting Tools.....	11
Hydraulic Circuit.....	12, 13
Reversing Valve Chokes.....	14, 15
Motor and Pump.....	15
Pump Maintenance Instructions	16-23
Pump Service Parts Information	24-29
Flow Control and Overload Relief Valves	30
Valve Maintenance.....	31, 32
Valve Parts Drawing.....	33-36
Specifications.....	37
Maintenance - Lubrication.....	38
Lubrication Chart.....	39
Parts List.....	40- 65

LIST OF ILLUSTRATIONS

Figure	Title	Page
1	Right Side with Plain Table.....	41
2	Left Side with Universal Table.....	42
3	Tool Head.....	44
4	Power Downfeed - Optional.....	46
5	Main Crossrail Unit.....	48
6	Crossrail Gear Box.....	50
7	Crossrail Feed and Rapid Traverse.....	52
8	Crossrail Vertical Feed.....	54
9	Universal Table - Optional.....	56
10	Pilot Valve and Trip Dogs.....	58
11	Combination Valve and Controls.....	60
12	Hydraulic Valves.....	62
13	Ram Cylinder.....	64
14	Safety Crank.....	65

INSTRUCTIONS FOR REQUISITIONING PARTS

NOT IDENTIFIED BY NSN

When requisitioning parts not identified by National Stock Number, it is mandatory that the following information be furnished the supply officer.

- 1 - Manufacturer's Federal Supply Code Number - 51292
- 2 - Manufacturer's Part Number exactly as listed herein.
- 3 - Nomenclature exactly as listed herein, including dimensions, if necessary.
- 4 - Manufacturer's Model Number - Model
- 5 - Manufacturer's Serial Number (End Item)
- 6 - Any other information such as Type, Frame Number, and Electrical Characteristics, if applicable.
- 7 - If DD Form 1348 is used, fill in all blocks except 4, 5, 6, and Remarks field in accordance with AR 725-50.

Complete Form as Follows:

(a) In blocks 4, 5, 6, list manufacturer's Federal Supply Code Number - 51292 followed by a colon and manufacturer's Part Number for the repair part.

(b) Complete Remarks field as follows:

Noun: (nomenclature of repair part)
For: NSN: 3418-00-808-0475
Manufacturer: Rockford Machine Tool Co.

Model:
Serial: (of end item)

Any other pertinent information such as Frame Number, Type, Dimensions, etc.

SERVICE MANUAL
for the
INSTALLATION OPERATION
and
MAINTENANCE
of the
HORIZONTAL, METAL CUTTING
Hy- Draulic **SHAPER**
16 inch

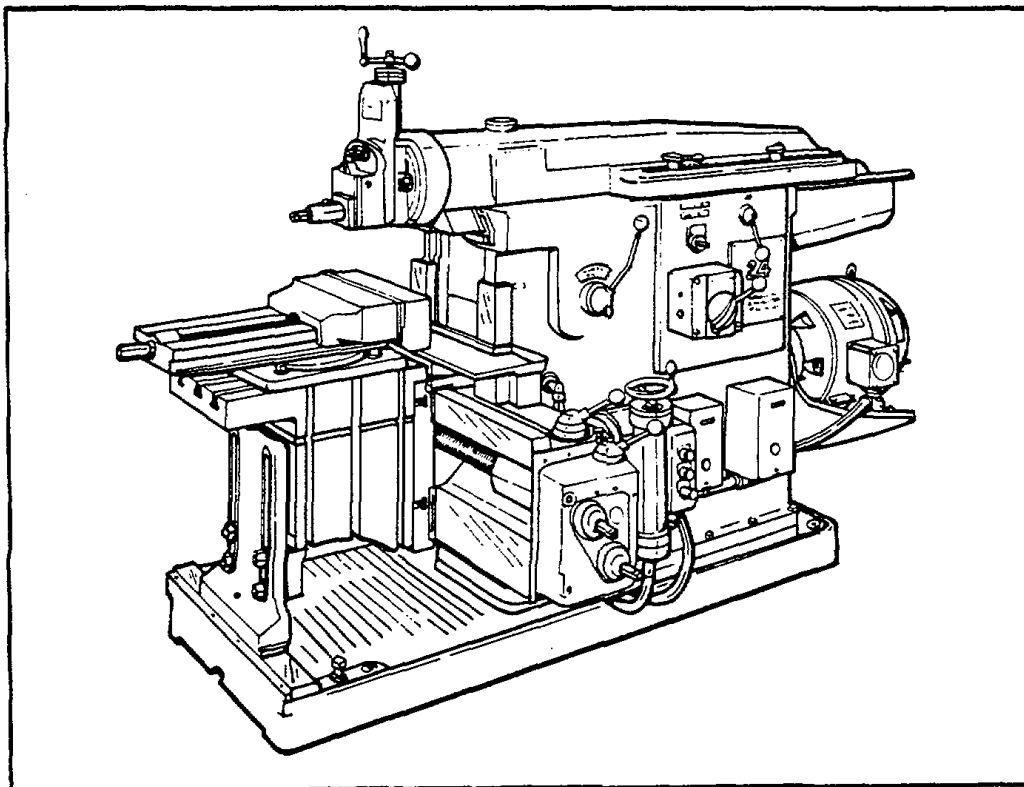

Series 15

RECEIVING

Before accepting the machine, a preliminary examination should be made for any possible damage in transit. If there is evidence of such damage a notation to that effect should be made on the receipt and the machine received subject to thorough inspection. When the extent of the damage has been determined, your reports should be filed.

HANDLING

The best method of handling the shaper is by means of a crane with adequate capacity. By removing the top boards of the crate and the water proof covering, a rope or sling may be attached as shown. The sling should be crossed over the crane hook to prevent slipping. A sling to carry a load of at least 10,000 pounds should be used. If no crane is available rollers must be used. In moving the machine on rollers leave the skids attached until it has reached the place of installation. Always be careful that the ends of the skids do not drop off a roller as damage to the machine may result.

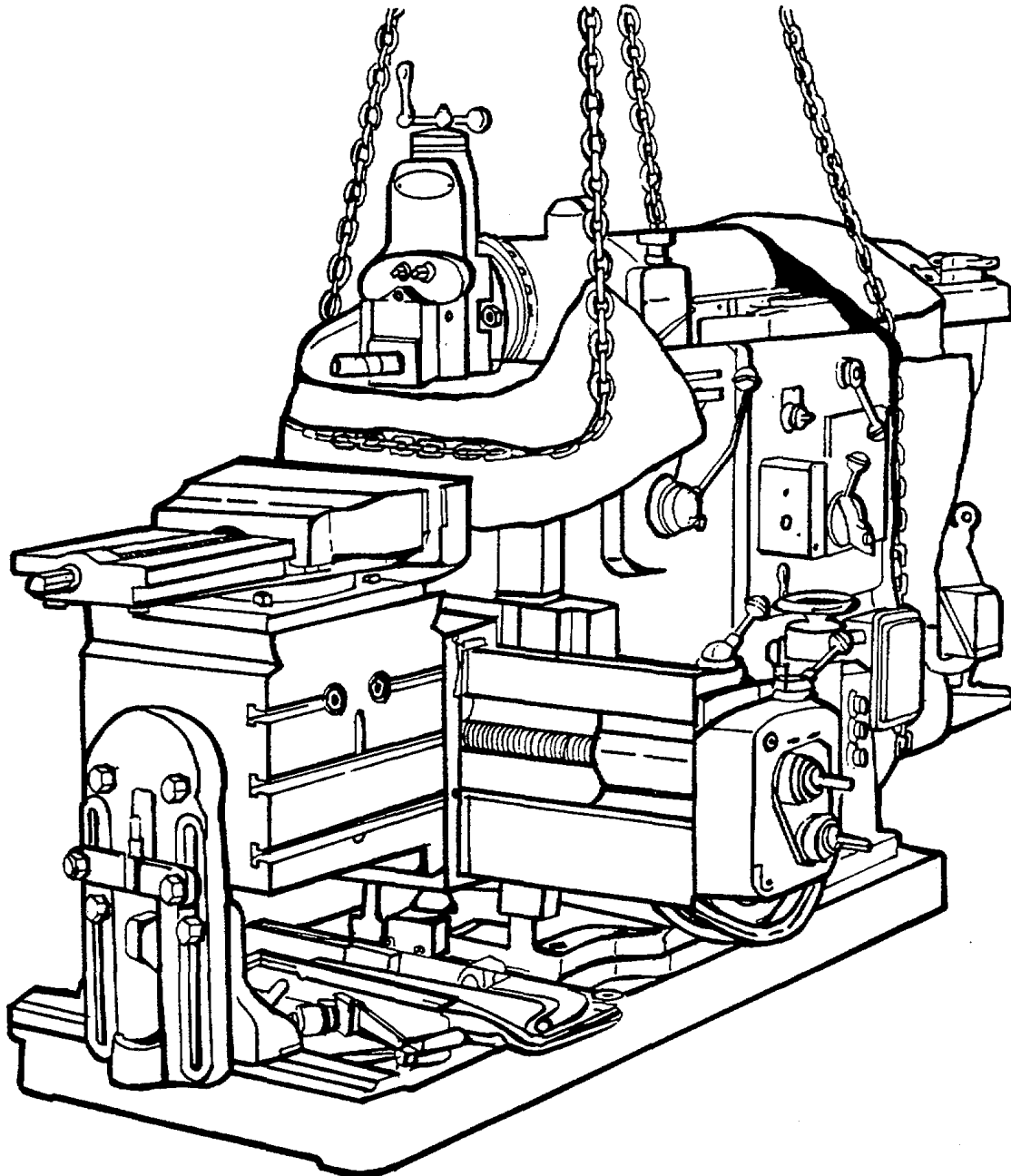

CLEANING

Before shipment, all unpainted surfaces were coated with a rust preventive compound. This may be removed by wiping with rags saturated with a nonflammable cleaning fluid. Clean only by wiping and brushing. Do not use compressed air as this tends only to force dirt and grit into the working parts.

After the slushing compound has been removed, wipe all finished surfaces with a cloth moistened with lubricating oil. Do not move any of the controls or moving parts until the machine has been thoroughly cleaned and lubricated.

INSTALLATION

The first consideration in maintaining the accuracy of any machine tool is to see that it is supported by a rigid foundation. For a machine of this size a concrete floor furnishes sufficient foundation. Anchor bolts should be embedded in the concrete.

Holes for six anchor bolts are provided in the base plate, one pair near the front end, one pair at the front corner of the column, and one pair at the rear corner. Level the machine by using steel wedges under the base plate near the anchor bolts at the four corners of the column, leaving the front end of the base plate free. For crosswise leveling use the finished top of the cross rail. For lengthwise leveling use the finished top of the column along the ram ways. Use a precision machine level. A carpenter's or mason's level is not sufficiently accurate for this purpose. When the machine has been leveled from these four points, tighten the nuts on those four anchor bolts. Then, with the leveling screws at the front of the base plate make adjustment until the plate on which the outer table support slides is exactly parallel to the cross rail and tighten the screws on the two front anchor bolts.

With a rich mixture of portland cement and clean building sand and enough water to make a thick mixture (grout) fill the space between the base plate and the floor using sufficient grout around the outside to embed the base plate to a depth of one inch or more. Allow sufficient time for the grout to harden before starting the machine. On a machine having a plain table the entire base plate may be embedded in grout as shown.

The universal table requires clearance so that the outer table support may be lowered to the bottom surface of the base plate. Therefore the space across the front end of the base plate should be filled with grout only up to the bottom surface of the plate.

The floor plan on the following page is typical of the area and shape of the space required. For actual installation use only the certified print which is mailed prior to shipment of the machine.

If a concrete foundation is to be built, consideration should be given as to whether or not conduit for electric wiring is to be embedded. The floor plan shows the location of the entrance of electric wires.

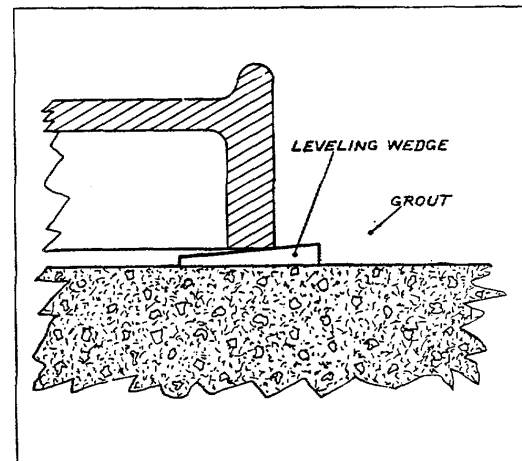

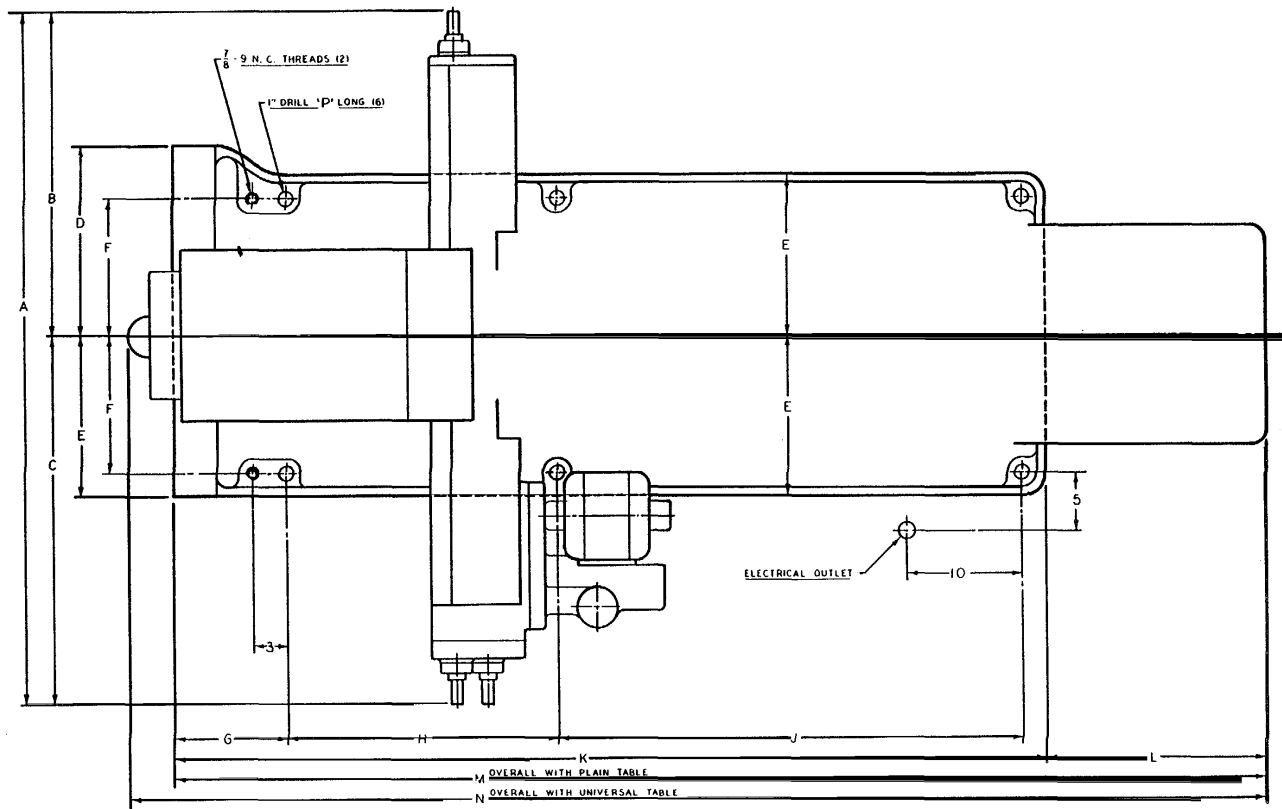

MACHINE	A	B	C	D	E	F	G	H	J	K	L	M	N	P
16"	56-1/4	25-1/4	31	13-1/2	13-1/2	11-1/2	9	17-1/2	40-1/4	6.9	18	87	91	3-5/8

ELECTRICAL CONNECTIONS AND WIRING

The electrical system of the hydraulic shapers consists of a motor for driving the main hydraulic pump, a motor to power the table traverse and rail elevation, together with suitable push button station and magnetic switches for starting the motors.

A wiring diagram shows the wiring which is considered standard; however, for your individual machine use only the wiring diagram furnished for that machine.

When connecting the line wires to the control panel, jog the motors slightly to see that they run in the direction indicated by the arrows attached to them. Remember that as yet the hydraulic system has no oil in it, therefore any more than a slight jogging of the motor will be courting injury to the pump.

HYDRAULIC OILS

The oil used in the hydraulic system must be of a type proven suitable for the purpose. It should not foam nor emulsify under constant agitation, should have high resistance to oxidation, and must be free from lint, chips, water, sludge, and all other foreign substances. In addition it should meet the following specifications:

Viscosity Index	73 Min.
Viscosity	300 S. S. U. at 100° F.
Pour Point.....	10 F. Max.
Flash.....	355° F. Min.
Fire	405° F. Min.

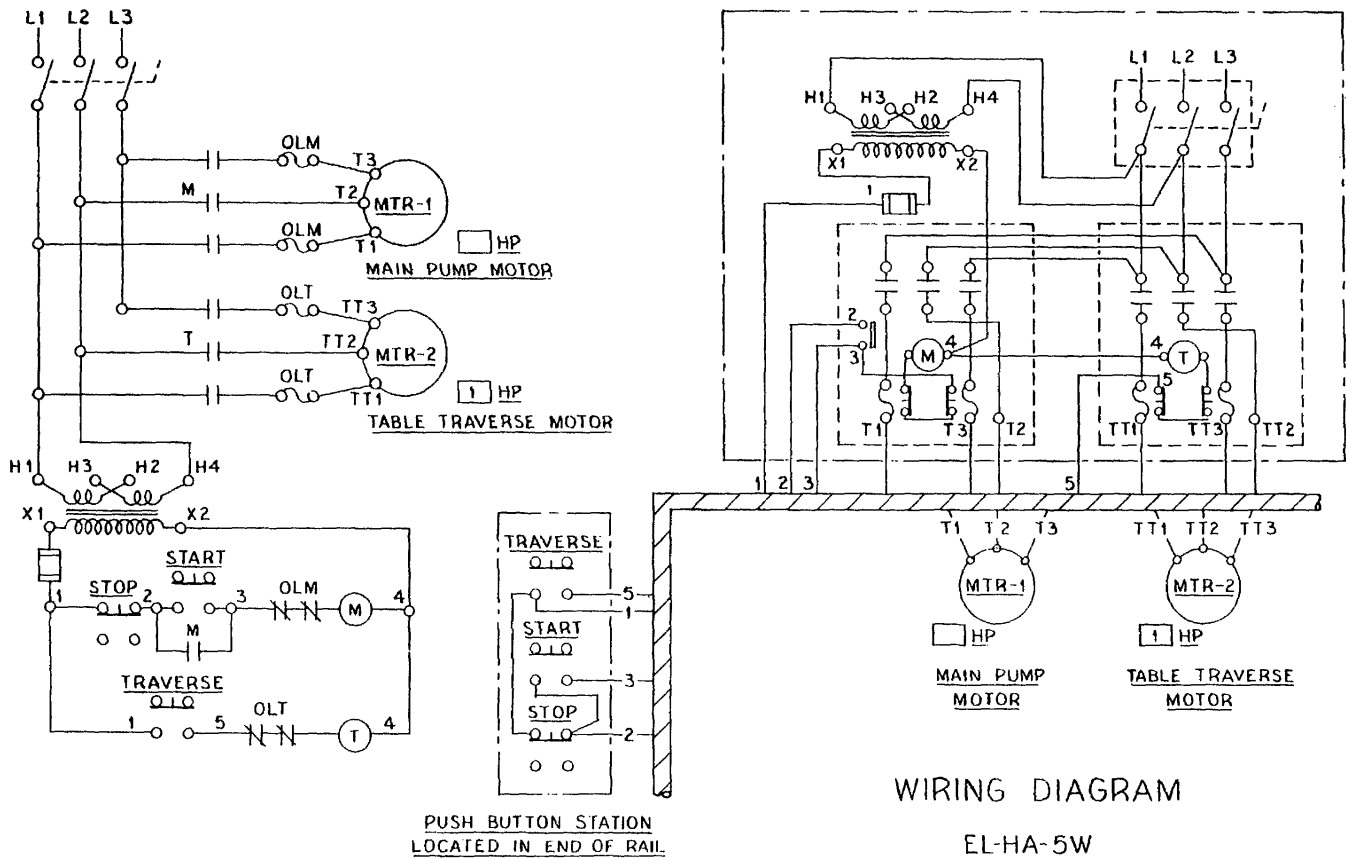

FILLING OIL RESERVOIR

For filling the oil reservoir it is recommended that a 30 gallon drum of an approved oil be obtained.

The oil may be poured through the rectangular opening in the cover plate on the left side of the machine column. Pour in sufficient oil to bring the level up to the mark on the gauge at the lower rear corner of the column. This will be sufficient until after the machine has been started. At that time more oil must be added since a considerable quantity will be drawn from the reservoir to fill the pump, valves, piping and cylinder.

Use only clean new oil and clean containers for handling it.

STARTING THE MACHINE

Before starting the machine, lubricate it thoroughly as directed in the section LUBRICATION. When ready to start, set the ram selector lever in the STOP position and the table selector and clutch engaging lever in the OFF positions. The stroke control knobs should be well toward the ends of their slot to give the ram a long stroke. Set the flow control lever about midway across its dial.

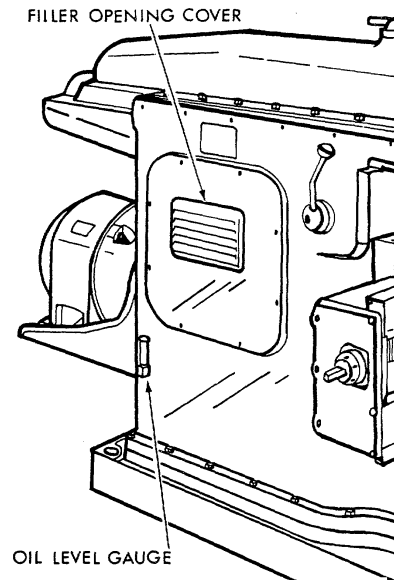

Start the main driving motor by pressing the START button of the control station. Allow the motor to run idle for a minute or two to prime the pump and build up pressure which starts the oil flowing through the overload relief valve. Shift the ram start-stop lever to the LOW position to set the ram into motion. If at first the ram action is unsteady, it is due to the air in the system. If allowed to run for a few minutes, the air will be worked out and the ram will have a steady motion with smooth reversals.

After the first few strokes observe the ram ways to see that a film of oil is covering their surfaces. If the ram ways are dry, stop the machine immediately and investigate as instructed in the section LUBRICATION.

The machine has now been prepared for operation and therefore the motor should be stopped by pressing the STOP button and returning all control levers, to their OFF or STOP positions. When the oil has come to rest, check the level in the oil gage and add whatever is necessary to again bring it up to the correct height. It may be one half inch above or below the mark on the gage without danger.

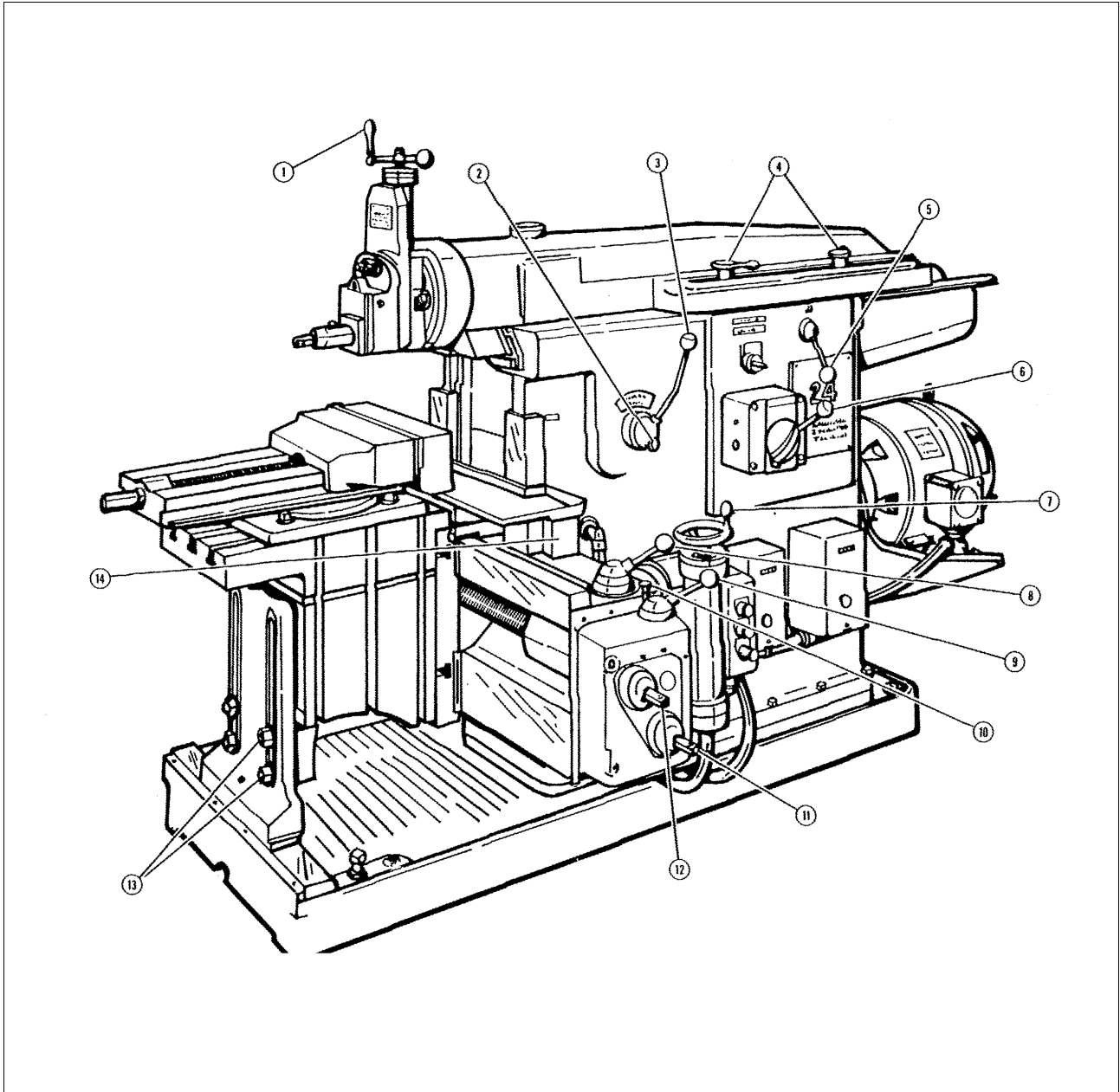

OPERATING THE MACHINE

All control levers and adjustments are grouped within a small space, making them convenient to the operator's reach.

Identification numbers of the various controls shown in illustration on opposite page are as follows:

1. The ball crank on the top of the vertical feed screw is for manually feeding the tool head up or down. Directly below the crank is a graduated collar which shows the amount of travel. Each graduation of the dial represents a movement of one thousandth (0.001) inch of the tool head.

When so ordered a power feeding mechanism is furnished for the tool head. A description of the power vertical feed is given on page 15.

2. This knob and plunger must be pulled outward to allow lever 3 to be shifted to the high speed range position.

3. This lever starts, stops, and selects the speed of the ram. There are two ranges of speed, high and low. Within each range lever 6 provides infinitely variable speed changes. The dial on lever 3 is marked to show the setting for the various functions.

4. The length and position of the ram stroke is determined by the setting of these knobs. On the inside of the ram and attached to these knobs are the reversing cams which actuate the pilot valve for reversing the ram stroke. The knob at the rear reverses the ram at the end of the cutting stroke while the one at the front reverses on the return stroke.

5. Reversal of the direction of ram stroke at any point during either cutting or return is accomplished by means of this lever. To become acquainted with the advantages of this lever, start the ram into motion with a long, slow stroke. When the ram has reached a point about midway in the cutting stroke shift this lever toward the rear and note that the ram immediately reverses. Shifting toward the front has the same effect during the return stroke.

As an example of the value of this feature, suppose that the feed had been set to an amount greater than the power of the machine could accommodate and the ram stalled in the cut. By simply shifting this lever the tool is backed out to permit adjustment of the difficulty. Other advantages will be discovered as experience is gained in the operation of the machine.

6. The valve operated by this lever varies the quantity of oil delivered to the ram cylinder and thereby governs the ram speed. The valve operates in the same manner in both the high speed and low speed ranges which are selected by lever 3.

Shifting the lever toward the front decreases the ram speed; toward the rear increases it. By using levers 3 and 6 in conjunction with each other any speed, from the lowest in the low speed range to the highest in the high speed range, may be obtained. When operating in the high speed range, the flow of oil to the cylinder must not be reduced below the low speed range.

7. The amount of cross or vertical feed to the table is regulated by this handwheel. Screwing it down decreases the feed, up, increases it. The selection as to vertical or cross feed is made by the setting of lever 8.

8 and 9. These two levers are used in conjunction with each other. Lever 9 selects the setting for either vertical or horizontal movement of the table and after it has been set lever 8 selects the direction of motion for that setting.

Shifting lever 9 to the left engages the vertical travel and then lever 8 selects the upward or downward travel of the table and cross rail. Shifting lever 8 to the left or FORWARD position raises the rail, to the right or REVERSE lowers the rail.

If lever 9 is set to the right or CROSS position and lever 8 to the FORWARD position the table will travel toward the rear or away from the operator. Shifting lever 8 to the REVERSE position causes the table to move toward the operator. These settings apply to both the feeding and power traverse mechanisms. When using the power traverse be sure that the traverse motor is STOPPED before shifting the levers. When using the hand safety crank set both levers 9 and 8 to the OFF position.

10. This knob must be pulled up to shift lever for vertical travel of rail.

11. When the cross rail is to be raised or lowered by hand, the safety crank furnished is to be used on this shaft. When using the hand crank lever 9 must be in the OFF position and the upper plates which clamp the cross rail to the column must be released. The graduated collar on the shaft indicates the amount of movement of the rail. Each graduation indicates a movement of one thousandth (0.001) inch. A setscrew in the knurled rim may be used for locking the dial at any setting.

12. This is the screw for moving the table along the cross rail. The squared end is to receive the safety crank for hand operation. When using the crank lever 9 must be in the OFF position. The graduated collar on the screw indicates the amount of movement of the table. Each graduation indicates a movement of one thousandth (0.001) inch. A setscrew in the knurled rim may be used to lock the dial at any setting.

The screw projects through the opposite end of the cross rail permitting the use of the crank at either end.

Directly behind the feed cylinder is an electric motor to supply power for the rapid traverse of the table either vertically or horizontally. The motor is started and stopped by using the TRAVERSE button on the control station. The motor will run only as long as the button is held in contact.

The direction of both feed and traverse is determined by the setting of levers 8 and 9.

13. Before lowering the table be sure to loosen the clamp nuts on the outboard support, and the two clamp nuts behind the rail. After the table has been moved to the desired position these nuts should be tightened in order to provide a rigid support for the table during the planing operation.

14. At the rear of the cross rail and holding it to the column are four plates, two on either side. The lower plates are scraped to a sliding fit and need no attention during the operation of the machine.

The top plates are so made that the rail may be clamped to the column by tightening the nuts which hold the plates in position. When raising or lowering the rail the clamp plates must be loosened.

When shaping is to be done with the rail in a stationary position the clamp plates should be tightened to provide greater rigidity to the work table.

UNIVERSAL TABLE

The hydraulic shaper is furnished with a plain table as standard equipment, however, a universal table is available as alternate equipment when so ordered.

The universal table has a tilting top which is adjustable 15 degrees in either direction. To tilt the top loosen the clamping nuts(14)on both sides of the table. Unscrew and remove locating block(18);then, with the hand crank on worm shaft(19),tilt the table to the desired position reading the angle on etched plate (22). Tighten clamping nuts (14)before doing any cutting.

The table also revolves on its trunnion through a complete revolution of 360 degrees. To revolve the table loosen clamp nuts(15)and unscrew and remove tapered dowel pin (21). With a crank on worm shaft(16 or 20)the table may be rotated to the desired angle which is read on the graduations at (117).Tighten clamp nuts (15)before doing any cutting.

When the table is returned to the upright position dowel pin(21) may be replaced thereby assuring the exact positioning of the table.

If the table is rotated 90 degrees to the left it will present a large flat working surface with T slots similar to a plain table.

When raising or lowering the table do not forget to loosen the clamp nuts on the outboard table support.

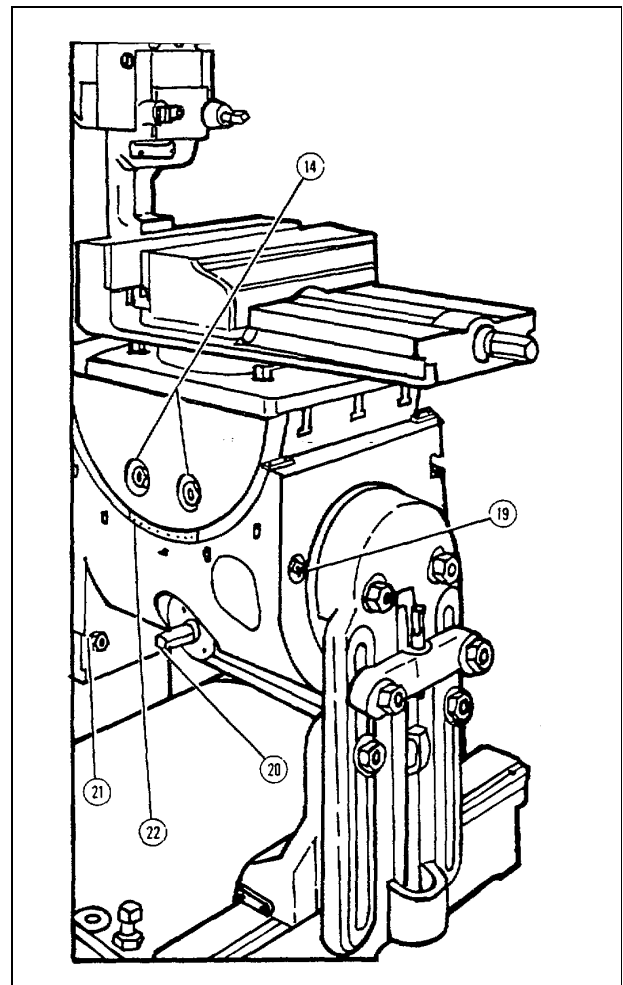
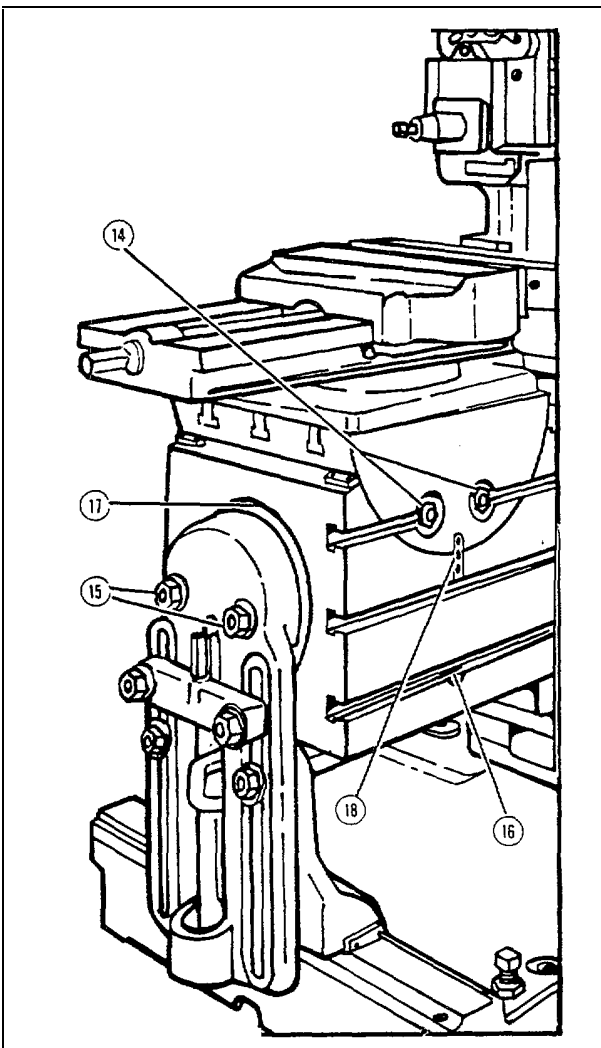

TOOL HEAD POWER FEED

The attachment providing power vertical feed to the tool head is not standard equipment but is applied to machines when so ordered.

The attachment consists of an adjustable cam or shoe attached to the column, and an arm and roller riding over the cam, and connected to the vertical feed screw of the tool head

The direction of feed, up or down, is selected by a lever mounted on the top of the ram.

The amount of feed is regulated by a screw with a knurled knob mounted on the side of the ram. Turning the screw downward decreases the amount of feed; upward increases it. The amount of feed is indicated by the graduated collar at the top of the vertical feed screw.

The actuating cam on the top of the column is adjustable forward and backward and should be set so that the feeding action takes place just before the end of the return stroke of the ram.

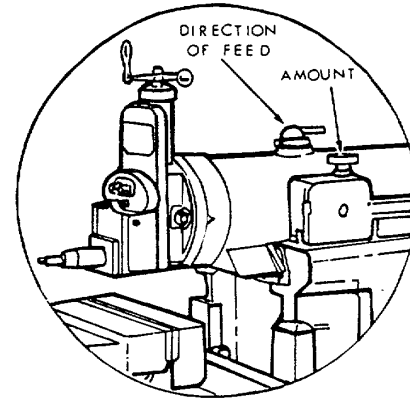

CUTTING TOOLS

The conventional types of cutting tools are suitable for use on this machine.

Plain forged tools may be used or the inserted bit type of tool holder sets may be obtained from any of several manufacturers of such articles.

If formed tools are to be used they, of course, must be made to suit the job in hand.

HYDRAULIC CIRCUIT

The diagram below shows the general principle on which the circuit operates. It does not show the details of piping on the machine.

Before shipment of the machine adjustments were made to assure the correct functioning of all parts. Further adjustments should be unnecessary and may be detrimental to the smooth operation of the machine,

Illustrations on the following pages show the actual piping of the circuit.

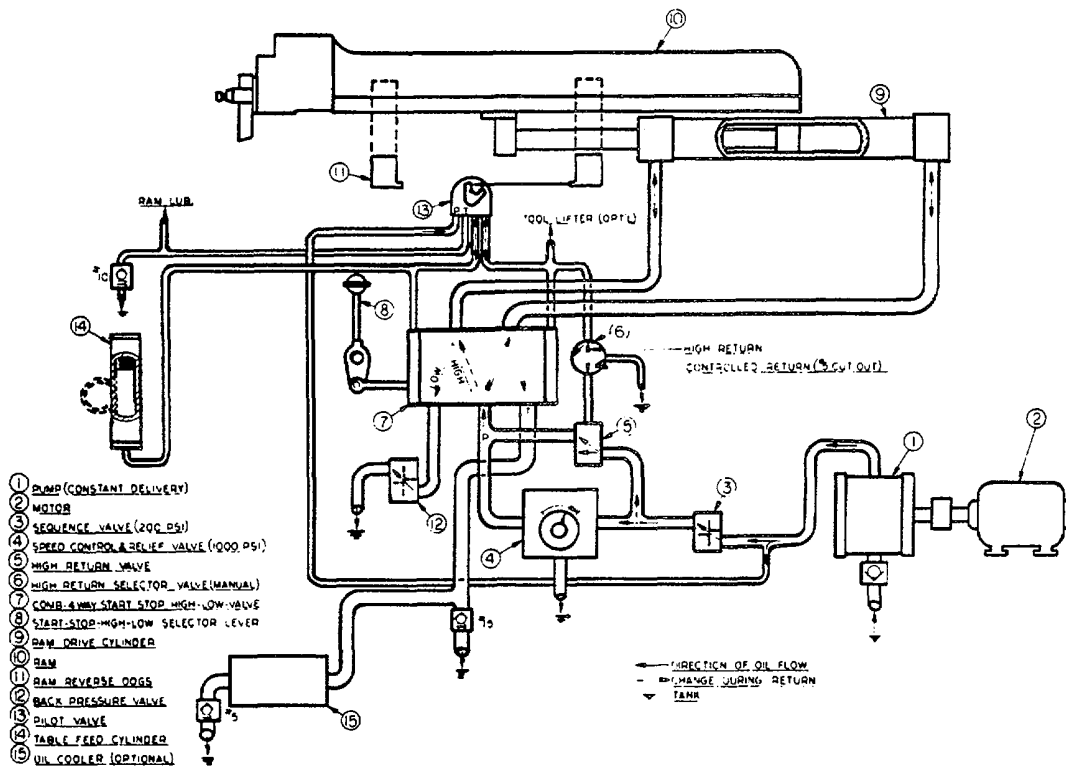

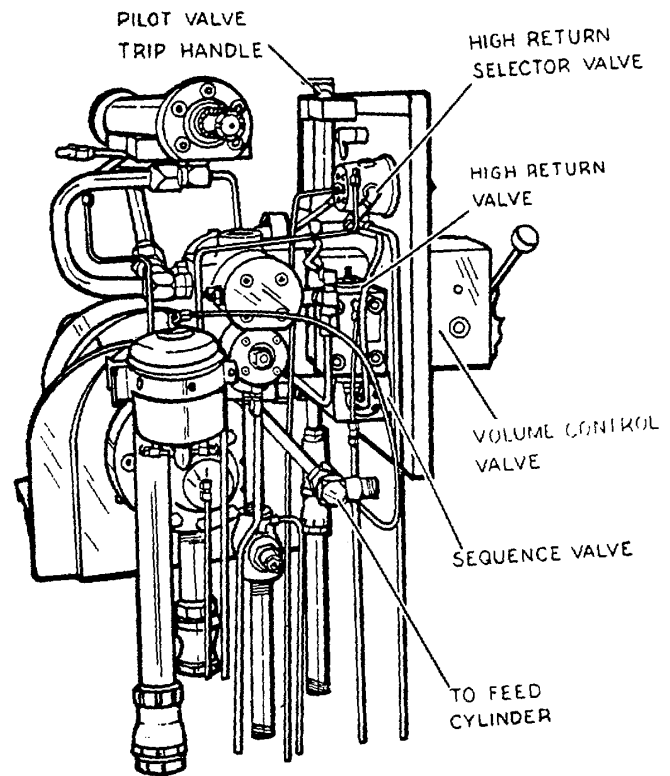
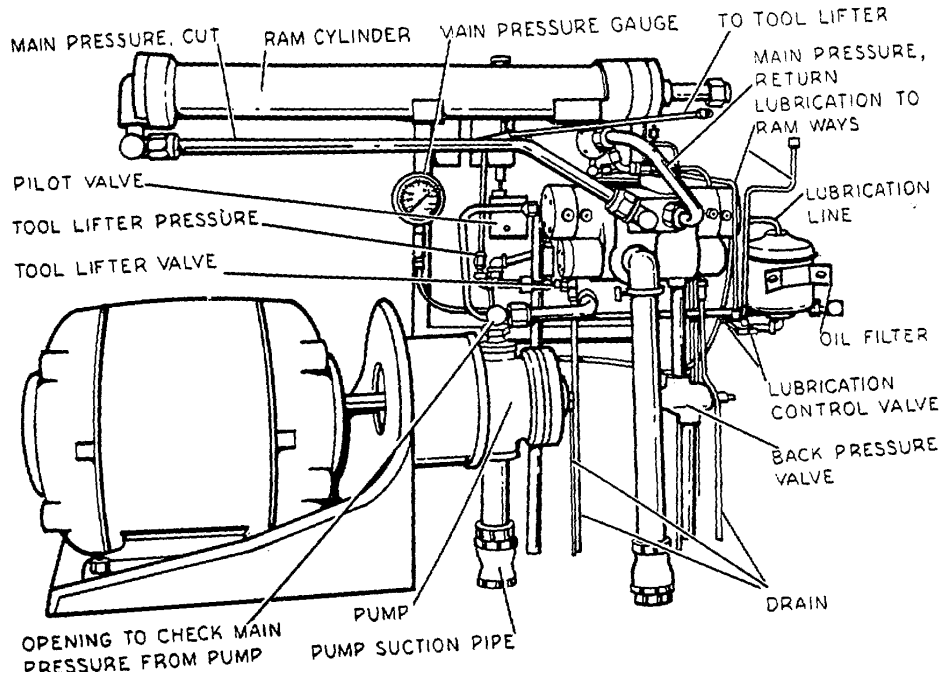

REVERSING VALVE CHOKES

On the main valve body are placed four choke plugs, two at each end, for the purpose of adjusting the ram reversals at each end of its stroke. By means of these chokes the rate of deceleration at the end of the stroke may be controlled. Likewise the rate of acceleration at the beginning of the stroke may be controlled.

These chokes are adjusted by experts at our factory to give the most suitable ram action under the conditions existing here. No further adjustment should be necessary and the chokes should not be tampered with.

However, in rare cases, the conditions under which the machine must operate in a customer's plant may require a slight readjustment of the chokes. If such a case arises no one except a thoroughly experienced mechanic should attempt to change the setting.

The following is offered in explanation of the functioning of the choke plugs.

They operate on the principle of a needle valve for governing the rate at which oil may be discharged from the space at the ends of the reversing valve spool, and therefore the speed at which the valve spool travels during the shifting action. If the chokes are open too far the ram will reverse with a shock or bump at the end of the stroke; if closed too much the ram will be sluggish in its action.

Chokes 3 and 4 control the reversal of the ram at the end of the cutting stroke and beginning of the return stroke. Chokes 1 and 2 control the reversal at the end of the reverse stroke and beginning of the cutting stroke. When the correct adjustment has been made the ram will have a snappy action but still without shock.

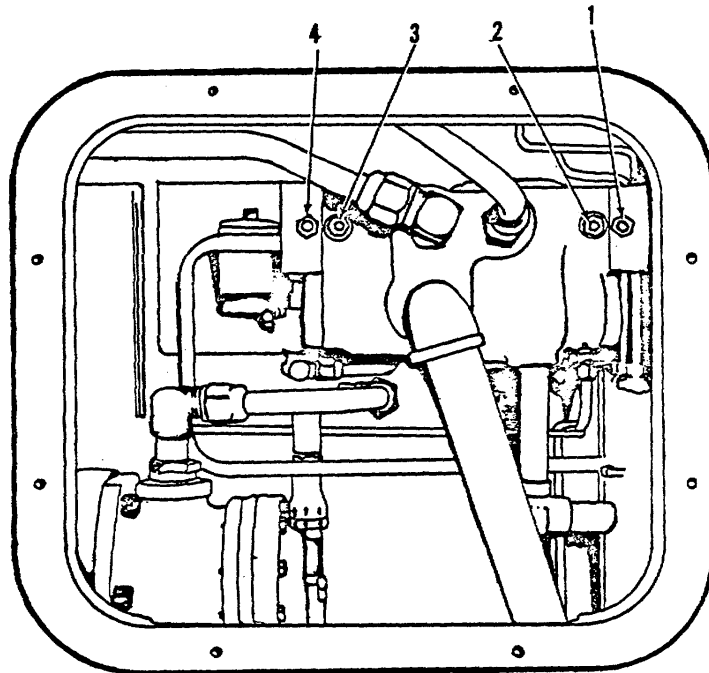

It was stated previously that no one except a thoroughly experienced mechanic should be allowed to make adjustments. This is for the reason that no exact formula can be given for setting the chokes. It is more a matter of gaining experience in the results obtained with different settings. However, it can be explained that screwing the chokes inward will slow up the ram action, while opening them will produce sharper reversals. Adjustments should be made slowly and carefully so that the result of each slight turn may be observed.

Care must be taken to see that chokes 2 and 3 are not screwed in too far as this would cause damage to the valve spool and the choke.

The chokes become accessible by removing the square door from the left side of the column.

Before starting to make adjustments the feed cylinder should be entirely closed off either by closing the valve at the bottom of the cylinder or by screwing the feed adjusting screw down so that the feed piston has no movement.

For the first adjustment of the chokes the ram should be set for the shortest possible stroke and adjustments made for the low and high ram speeds. Then set the reversing dogs for a long ram stroke and observe that it may be necessary to open the chokes slightly to get the best action. The ideal setting is to strike a balance between the short stroke at high speed and the long stroke at low speed.

MOTOR AND PUMP

The Hy-Draulic shaper is powered by an electric motor directly connected to the hydraulic pump by a flexible type coupling. On the 16", 20" and 24" standard a 7 1/2 H. P motor is used. The 24" Heavy and 28" carry a 10 H. P. motor.

On direct current or 60 cycle alternating current the motor runs at 1200 R.P.M., on 50 cycle at 1000 R.P.M., and on 25 cycle at 750 R.P.M.

On the 16', 20' and 24' standard the pumps are as follows:

- 1200 R. P. M. Model V-135-20
- 1000 R. P. M. " V-135-U-20
- 750 R. P. M. " V-135-X-20

On the 24' Heavy and 28' the following pumps are used:

- 1200 R. P. M. Model V-135-X-20
- 1000 R, P. M. " V-145-20
- 750 R. P. M. " V-145-20

Installation and maintenance information on all pumps is given in Bulletin 1-133744 and I-3100S. Parts are listed on parts drawing I-3102S. Both of these publications are included in this book.

Sequence valve pressure is set at 250 lbs. with pump running and ram stopped.

Main pressure is set at 1000 lbs. with ram stalled in cut or at the end of stroke.

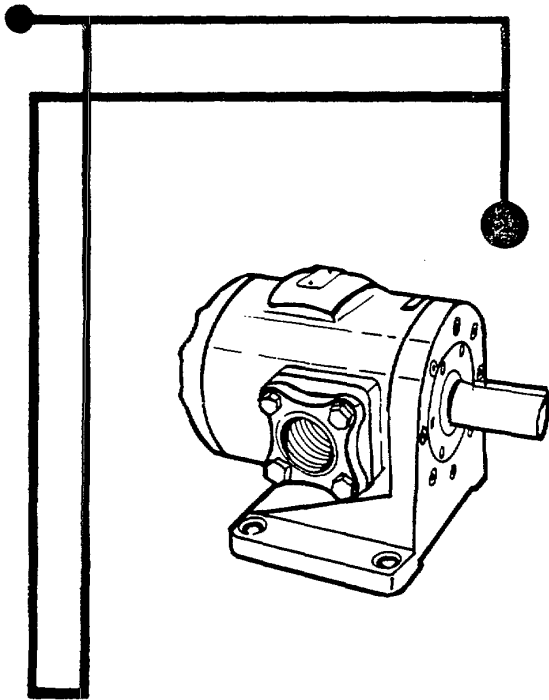

**SERVICE
AND
MAINTENANCE INSTRUCTIONS**

**SINGLE STAGE
SINGLE AND DOUBLE
VANE PUMPS**

OPERATING CHARACTERISTICS

TYPEBalanced Vane, Fixed Delivery **OPERATING FLUID** 150 S.S. U. at 100°F
SERIESSingle and Double, Single Stage **MOUNTNG**Face, Foot, Flange, Electric
OPERATING PRESSURE See Performance Data Motor End Bell
INPUT SPEED, RPM..... See Performance Data **CONNECTIONS** Pipe Thread Body Ports or Flanges

Performance data is based on input speed at 1200 rpm , pumping petroleum base fluid at 1200 F. Minimum recommended drive speed for all series is 600 rpm,. Characteristics at other drive speeds are approximately proportional to rpm . For performance data when using! other than petroleum base fluids, see applicable Installation drawing , shown on page 25.

Head Bolt Torque in Inch Pounds Minimum	Model Numbers		Recom- mended Drive Speed maximum rpm	Delivery, gpm at 1200 rpm			Horsepower Input at 1200 rpm		
	Foot Mounting	Flange Mounting		0 psi	500 psi	1000 psi	0 psi	500 psi	1000 psi
SMALL SERIES 50 Inch lbs.	V-104-Y-10	V-105-Y-10	1800	1.8	1.5	1.1	.20	0.9	1.5
	V-104-E-10	V-105-E-10	1800	2.7	2.4	2.0	.25	1.2	2.2
	V-104-G-10	V-105-G-10	1800	3.7	3.4	3.0	.25	1.4	2.6
	V-104-A-10	V-105-A-10	1800	5.3	5.0	4.7	.30	1.9	3.6
	V-104-C-10	V-105-C-10	1500	8.2	7.9	7.5	.35	2.8	5.2
	V-104-D-10	V-105-D-10	1200	11.5	11.0	10.6	.40	3.7	7.0
INTER-MEDIATE SERIES 150 Inch lbs.	V-124-20	V-125-20	1500	15.4	14.5	13.6	.70	5.8	10.9
	V-134-20	V-135-20	1500	19.5	18.8	18.0	.75	6.7	12.4
	V-134-U-20	V-135-U-20	1500	23.0	22.2	21.3	.80	8.1	14.9
	V-134-X-20	V-135-X-20	1200	29.9	28.9	27.8	1.00	9.7	18.8
	V-144-20	V-145-20	1200	37.9	35.5	35.0	1.20	13.5	24.1
LARGE SERIES 150 Inch lbs.	VF-40-10	VG-40-10	1200	41.7	39.5	37.2	1.6	14.0	26.5
	V-360-10	V-361-10	1200	48.5	46.8	45.0	2.0	16.5	31.5
	V-460-10	V-461-10	1200	60.6	58.3	56.0	2.7	20.4	38.4

DOUBLE PUMP SERIES - SINGLE STAGE
Small Series Combination

Model Numbers.		Small Volume - Head End Pump						Large Volume - Shaft End Pump					
Foot Mounting	Flange Mounting	delivery gpm			hp input			delivery gpm			hp input		
		0 psi	500 psi	1000 psi	0 psi	500 psi	1000 psi	0 psi	500 psi	1000 psi	0 psi	500 psi	1000 psi
V-108-YY-10	V-109-YY-10							1.8	1.5	1.1	.20	0.9	1.5
V-108-YE-10	V-109-YE-10							2.7	2.4	2.0	.25	1.2	2.2
V-108-YG-10	V-109-YG-10	1.8	1.5	1.1	.20	0.9	1.5	3.7	3.4	3.0	.25	1.4	2.6
V-108-YA-10	V-109-YA-10							5.3	5.0	4.7	.30	1.9	3.6
V-108-YC-10	V-109-YC-10							8.2	7.9	7.5	.35	2.8	5.2
V-108-YD-10	V-109-YD-10							11.5	11.0	10.6	.40	3.7	7.0
V-108-EE-10	V-109-EE-10							2.7	2.4	2.0	.25	1.2	2.2
V-108-EG-10	V-109-EG-10							3.7	3.4	3.0	.25	1.4	2.6
V-108-EA-10	V-109-EA-10	2.7	2.4	2.0	.25	1.2	2.2	5.3	5.0	4.7	.30	1.9	3.6
V-108-EC-10	V-109-EC-10							8.2	7.9	7.5	.35	2.8	5.2
V-108-ED-10	V-109-ED-10							11.5	11.0	10.6	.40	3.7	7.0
V-108-GG-10	V-109-GG-10							3.7	3.4	3.0	.25	1.4	2.6
V-108-GA-10	V-109-GA-10							5.3	5.0	4.7	.30	1.9	3.6
V-108-GC-10	V-109-GC-10	3.7	3.4	3.0	.25	1.4	2.6	8.2	7.9	7.5	.35	2.8	5.2
V-108-GD-10	V-109-GD-10							11.5	11.0	10.6	.40	3.7	7.0
V-108-AA-10	V-109-AA-10							5.3	5.0	4.7	.30	1.9	3.6
V-108-AC-10	V-109-AC-10	5.3	5.0	4.7	.30	1.9	3.6	8.2	7.9	7.5	.35	2.8	5.2
V-108-AD-10	V-109-AD-10							11.5	11.0	10.6	.40	3.7	7.0
V-108-CC-10	V-109-CC-10							8.2	7.9	7.5	.35	2.8	5.2
V-108-CD-10	V-109-CD-10							11.5	11.0	10.6	.40	3.7	7.0
V-108-DD-10	V-109-DD-10	11.5	11.0	10.6	.40	3.7	7.0	11.5	11.0	10.6	.40	3.7	7.0
Intermediate and Small Series Combination													
V-128-Y-20	V-129-Y-20	1.8	1.5	1.1	.20	0.9	1.5						
V-128-E-20	V-129-E-20	2.7	2.4	2.0	.25	1.2	2.2						
V-128-G-20	V-129-G-20	3.7	3.4	3.0	.25	1.4	2.6	15.4	14.5	13.6	.70	5.8	10.9
V-128-A-20	V-129-A-20	5.3	5.0	4.7	.30	1.9	3.6						
V-128-C-20	V-129-C-20	8.2	7.9	7.5	.35	2.8	5.2						
V-128-D-20	V-129-D-20	11.5	11.0	10.6	.40	3.7	7.0						
V-138-Y-20	V-139-Y-20	1.8	1.5	1.1	.20	0.9	1.5						
V-138-E-20	V-139-E-20	2.7	2.4	2.0	.25	1.2	2.2						
V-138-G-20	V-139-G-20	3.7	3.4	3.0	.25	1.4	2.6	19.5	18.8	18.0	.75	6.7	12.4
V-138-A-20	V-139-A-20	5.3	5.0	4.7	.30	1.9	3.6						
V-138-C-20	V-139-C-20	8.2	7.9	7.5	.35	2.8	5.2						
V-138-D-20	V-139-D-20	11.5	11.0	10.6	.40	3.7	7.0						
V-138U-Y-20	V-139U-Y-20	1.8	1.5	1.1	.20	0.9	1.5						
V-138U-E-20	V-139U-E-20	2.7	2.4	2.0	.25	1.2	2.2						
V-138U-G-20	V-139U-G-20	3.7	3.4	3.0	.25	1.4	2.6	23.0	22.2	21.3	.80	8.1	14.9
V-138U-A-20	V-139U-A-20	5.3	5.0	4.7	.30	1.9	3.6						
V-138U-C-20	V-139U-C-20	8.2	7.9	7.5	.35	2.8	5.2						
V-138U-D-20	V-139U-D-20	11.5	11.0	10.6	.40	3.7	7.0						
V-138X-Y-20	V-139X-Y-20	1.8	1.5	1.1	.20	0.9	1.5						
V-138X-E-20	V-139X-E-20	2.7	2.4	2.0	.25	1.2	2.2						
V-138X-G-20	V-139X-G-20	3.7	3.4	3.0	.25	1.4	2.6	29.9	28.9	27.8	1.00	9.7	18.8
V-138X-A-20	V-139X-A-20	5.3	5.0	4.7	.30	1.9	3.6						
V-138X-C-20	V-139X-C-20	8.2	7.9	7.5	.35	2.8	5.2						
V-138X-D-20	V-139X-D-20	11.5	11.0	10.6	.40	3.7	7.0						
V-148-Y-20	V-149-Y-20	1.8	1.5	1.1	.20	0.9	1.5						
V-148-E-20	V-149-E-20	2.7	2.4	2.0	.25	1.2	2.2						
V-148-G-20	V-149-G-20	3.7	3.4	3.0	.25	1.4	2.6	37.9	36.5	35.0	1.20	13.5	24.1
V-148-A-20	V-149-A-20	5.3	5.0	4.7	.30	1.9	3.6						
V-148-C-20	V-149-C-20	8.2	7.9	7.5	.35	2.8	5.2						
V-148-D-20	V-149-D-20	11.5	11.0	10.6	.40	3.7	7.0						

Large and Small Series Combination

Model Numbers		Small Volume - Head End Pump						Large Volume - Shaft End Pump					
Foot Mounting	Flange Mounting	delivery gpm			hp input			delivery gpm			hp input		
		0 psi	500 psi	1000 psi	0 psi	500 psi	1000 psi	0 psi	500 psi	1000 psi	0 psi	500 psi	1000 psi
VVF-1-40	VVG-1-40	1.8	1.5	1.1	.20	0.9	1.5	41.7	39.5	37.2	1.6	14.0	26.5
VVF-2-40	VVG-2-40	2.7	2.4	2.0	.25	1.2	2.2						
VVF-3-40	VVG-3-40	3.7	3.4	3.0	.25	1.4	2.6						
VVF-5-40	VVG-5-40	5.3	5.0	4.7	.30	1.9	3.6						
VVF-8-40	VVG-8-40	8.2	7.9	7.5	.35	2.8	5.2						
VVF-11-40	VVG-11-40	11.5	11.0	10.6	.40	3.7	7.0						
V-368-Y	V-369-Y	1.8	1.5	1.1	.20	0.9	1.5	48.5	46.8	45.0	2.0	16.5	31.5
V-368-E	V-369-E	2.7	2.4	2.0	.25	1.2	2.2						
V-368-G	V-369-G	3.7	3.4	3.0	.25	1.4	2.6						
V-368-A	V-369-A	5.3	5.0	4.7	.30	1.9	3.6						
V-368-C	V-369-C	8.2	7.9	7.5	.35	2.8	5.2						
V-368-D	V-369-D	11.5	11.0	10.6	.40	3.7	7.0						
V-468-Y	V-469-Y	1.8	1.5	1.1	.20	0.9	1.5	60.6	58.3	56.0	2.7	20.4	38.4
V-468-E	V-469-E	2.7	2.4	2.0	.25	1.2	2.2						
V-468-G	V-469-G	3.7	3.4	3.0	.25	1.4	2.6						
V-468-A	V-469-A	5.3	5.0	4.7	.30	1.9	3.6						
V-468-C	V-469-C	8.2	7.9	7.5	.35	2.8	5.2						
V-468-D	V-469-D	11.5	11.0	10.6	.40	3.7	7.0						
Large and Intermediate Series Combination													
VVSF-14-40	VVSG-14-40	15.4	14.4	13.3	.70	5.8	10.9	41.7	39.5	37.2	1.6	14.0	26.5
VVSF-18-40	VVSG-18-40	19.4	18.3	17.1	.75	6.7	12.4						
VVSF-22-40	VVSG-22-40	22.9	21.9	20.8	.80	8.1	14.9						
VVSF-28-40	VVSG-28-40	29.9	28.8	27.6	1.00	9.7	18.8						
VVSF-36-40	VVSG-36-40	37.8	35.9	33.9	1.20	13.5	24.1						
VVSF-14-48	VVSG-14-48	15.4	14.4	13.3	.70	5.8	10.9	48.5	46.8	45.0	2.0	16.5	31.5
V-350-FT	V-350-FL	19.4	18.3	17.1	.75	6.7	12.4						
VVSF-22-48	VVSG-22-48	22.9	21.9	20.8	.80	8.1	14.9						
V-353-FT	V-353-FL	29.9	28.8	27.6	1.00	9.7	18.8						
V-356-FT	V-356-FL	37.8	35.9	33.9	1.20	13.5	24.1						
VVSF-14-60	VVSG-14-60	15.4	14.4	13.3	.70	5.8	10.9	60.6	58.3	56.0	2.7	20.4	38.4
V-450-FT	V-450-FL	19.4	18.3	17.1	.75	6.7	12.4						
VVSF-22-60	VVSG-22-60	22.9	21.9	20.8	.80	8.1	14.9						
V-453-FT	V-453-FL	29.9	28.8	27.6	1.00	9.7	18.8						
V-456-FT	V-456-FL	37.8	35.9	33.9	1.20	13.5	24.1						

DESCRIPTION

This manual contains service and maintenance information for single and double pumps. These hydraulically balanced cartridge type vane pumps are used to provide a constant supply of hydraulic fluid under pressure and are produced in three basic housing sizes: small, intermediate and large. Cartridges of different displacement may be used interchangeably in each series. These pumps can be used as single units or two maybe assembled on a common drive shaft (double pump) providing an almost infinite number of combinations. Figure 1 illustrates a cross sectional view of a flange mounting, small and intermediate series combination double pump, assembled for LH rotation.

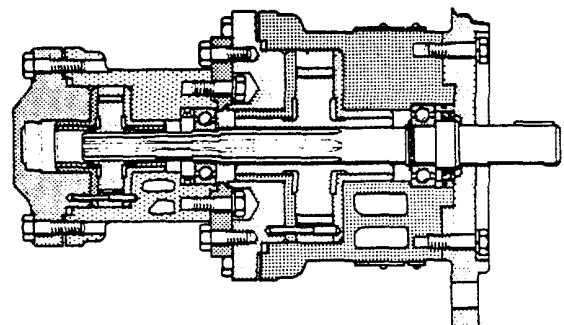

Figure 1

OPERATION

Operation: Pumping is performed by cartridges consisting of a ring, rotor, two bushings, twelve vanes and a locating pin or screws (see figure 2). The splined pump shaft rotates driving a slotted rotor. Vanes within the rotor slots are thrown out by centrifugal force and held out by system pressure to follow a double lobed cam ring. Movement of the vanes in and out as they follow the cam causes the chambers between them to increase in size and pick up fluid from the reservoir as the vanes cross the inlet porting. Chamber size decreases when the vanes cross the outlet porting forcing fluid out into the system.

The size of the cartridge ring determines the pump displacement. Ring change alters delivery. However, the 11 gpm ring in the small series and the 36 gpm ring in the intermediate series are used with wide vanes and rotor so conversions to these capacities require additional change of rotor, vanes and head.

Lubrication: None is required for current design models. Older designs require lubrication of the front shaft bearing. A grease fitting is provided on top the pump body. (Some of the larger pumps also incorporate a grease relief fitting on the bottom of the body.) It is recommended that these fittings be lubricated sparingly (approximately one tablespoonful every six months) with a low pressure gun using a

Complete overhaul may be accomplished by means of cartridge and gasket kits.

Disassembly may be accomplished in the order shown in the illustration (see figure 3 or 4).

WARNING

Before breaking any circuit connections, be certain the electrical power is off and the system is relieved of trapped pressure.

Prepare a clean, lint-free surface on which to lay internal parts of the pump. Thoroughly clean areas adjacent to the components being removed to minimize possibility of dirt entering the system. Cap or cover all exposed ports and openings into the system.

Inspect and replace as follows:

- a. Vanes, for wear and sticking in rotor slots. Vanes must move in slots from their own weight when dry. Replace if defective. Stone new vanes lightly on an India stone to remove sharp edges.
- b. Ring, for scored or cross-grooved cam face. Replace if grooved or scored.

Faces of rotor and bushings for wear and scoring.

good quality, high temperature, bearing grease.

CAUTION

Over-lubrication can damage the shaft seal.

Routine Inspection and Maintenance:

- a. Make certain all hydraulic *connections are* tight to prevent fluid leakage or entry of air into the system.
- b. Check fluid level in the reservoir to assure an adequate supply to the pump intake. When adding fluid, always pour it through a 200 mesh or finer screen.
- c. Inspect the filter element and replace if dirty.
- d. Inspect the fluid for contamination. If contaminated, drain the system and thoroughly clean the reservoir. Change the filters and flush the complete system with clean fluid. Again drain the system and refill with new fluid.
- e. Check the reservoir air breather and replace if dirty.

OVERHAUL

Remove light scores by lapping; replace if heavily scored. Stone new parts lightly to remove burrs.

- d. Bearings for cracked or pitted races or pitted balls. Replace if defective.
- e. Shaft for wear at seal lip journal. Replace if scored.
- f. Replace shaft seal, O ring and head packing at each teardown.

Reassembly: Assemble parts in reverse order of disassembly, noting the following:

- a. Assemble seals with spring toward inside of the pump.
- b. Coat all parts with compatible fluid and lightly lubricate the lip of the shaft seal to prevent damage during installation.
- c. Install bearing and snap ring on shaft end and place in the body.
- d. Spring in the shaft seal must be toward the shaft bearing.
- e. Install cartridge parts so arrows on the parts are pointed for intended rotation as viewed from the shaft end.
- f. Assemble the pin so its small diameter end fits into the body for RH rotation (large end in body for LH rotation). See installation page 23.

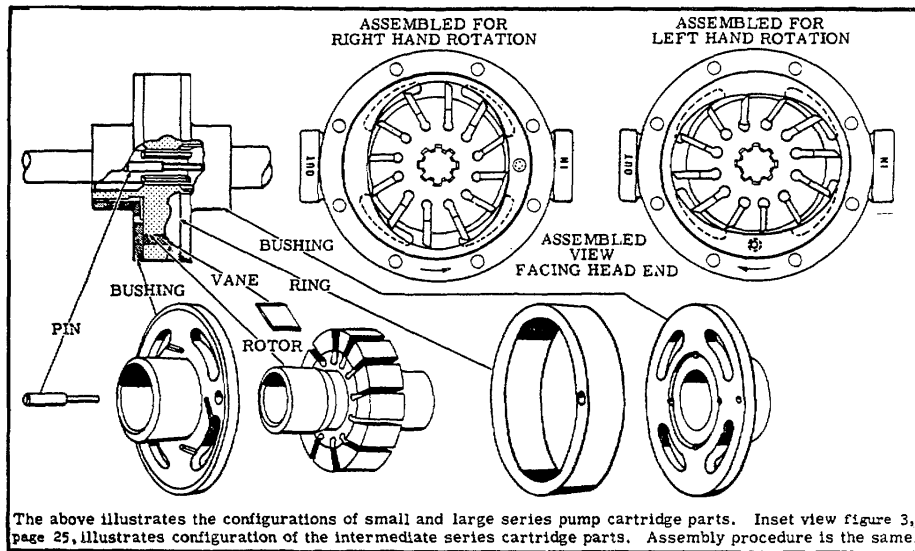

Figure 2
CARTRIDGE ASSEMBLY AND INSTALLATION

Figure 2 illustrates a typical cartridge assembly and installation, when viewed from the head end. The cartridge assembly procedure is the same for both single and double pumps, depending on the direction of shaft rotation.

The stepped diameter locating pin prevents improper assembly of the cartridge. However, caution must be exercised to install the cartridge properly for the direction of rotation desired.

The large series pump cartridges have a locating screw and a retaining screw in lieu of the locating pin used in the small and intermediate series.

NOTE

The direction of rotation (RH or LH) is always determined by viewing the pump from the shaft end.

INSTALLATION

Right hand rotation: Insert the small end of the locating pin into the small hole in the pump body at a 3 o'clock position.

Left hand rotation: Insert the large end of the locating pin into the large hole in the pump body at a 6 o'clock position.

HEAD SCREW ADJUSTMENT

Some pump cover heads and intermediate heads (double pumps) are provided with two small holes to match the two diameters of the locating pin. Install the head so the pin fits the hole size to prevent the pin from bending or shearing when the pump is put into operation.

Pull the head down gradually, alternately tightening the screws 180° from each other until the head seats evenly on the bushing. Turn the shaft by hand during the process until a light, smooth snugness is felt through a complete revolution. Do not over-tighten the screws, causing the shaft to bind.

Before starting these pumps, check for freedom of movement of the internal parts by turning the shaft by hand. Never start a pump which shows evidence of binding.

CAUTION

A new or overhauled pump must be started under load on the first run. This will create a back pressure to assure adequate internal lubrication. After a pump is broken in, it can be started under no-load conditions.

Start the pump by jogging the drive motor a few times to be sure the pump is primed.

If the pump is new or has been overhauled, be certain it is properly installed. Check the direction of shaft rotation and alignment of the shaft with the drive motor. Since it is difficult to achieve perfect shaft alignment, a flexible coupling must be used.

Exercise care with pumps driven by belts, chain drives, spur gears, etc. to prevent excessive side

loading of the drive shaft.

Pump life will be shortened by operation beyond maximum pressure and speed ratings. Since these units are positive displacement, a relief valve must be used to limit maximum system pressure to recommended limits.

TROUBLESHOOTING CHART

TROUBLE	PROBABLE CAUSE	REMEDY
PUMP NOT DELIVERING FLUID	Pump driven in wrong direction of rotation.	Must be reversed immediately to prevent seizure. Check direction of drive rotation against proper pump rotation as indicated by arrow on body.
	Pump drive shaft broken or shaft key sheared (direct drive).	Remove pump from accessory mounting pad and determine damage to pump cartridge. Replace needed parts.
	Fluid intake pipe in reservoir blocked or oil viscosity too heavy to pick up prime. Viscosity should not exceed 4000 S. S.U.	Drain complete system. Add new fluid of proper viscosity. Filter the new fluid as recommended. Check all filters for dirt and sludge.
	Air leaks at intake. Pump not priming. Oil level too low.	Check intake connection for air leak. Tighten securely. Loosen connection in outlet line. Bleed-off air until fluid flows. The fluid level must be above intake opening in intake pipe. Check minimum drive speed which may be too slow to prime the pumps.
	Vane or vanes stuck in rotor slots.	Inspect rotor slots for wedged chips or foreign particles and replace all damaged parts. Flush complete system thoroughly by recommended processes and fill system with new, clean hydraulic fluid.
PUMP MAKING NOISE	Partially clogged intake strainer or restricted intake pipe.	Pump must receive intake fluid freely or cavitation will result. Drain system, clean intake pipe, and clean or replace strainer. Add new fluid and strain by recommended procedures.
	Defective bearing.	Disassemble pump and replace bearing.
	Air leak at pump intake piping joints or pump shaft seal.	Test by pouring oil on joints and around drive shaft. Listen for change in operation. Tighten joints affected. Check pump shaft oil seal for leakage and replace if necessary, in accordance with instructions outlined in this manual. Check shaft for scoring at seal contact area and replace shaft if grooving is evident.
	Coupling misalignment.	Check shaft bearing and seal for possible damage. Replace if necessary. Re-align shafts.

The intermediate series, current design, cartridge parts are shown in the lower inset view. These modified parts provide better inlet conditions by

reducing wear and excessive noise due to cavitation. Thus permitting heavier viscosity fluids to be used while improving overall pumps performance.

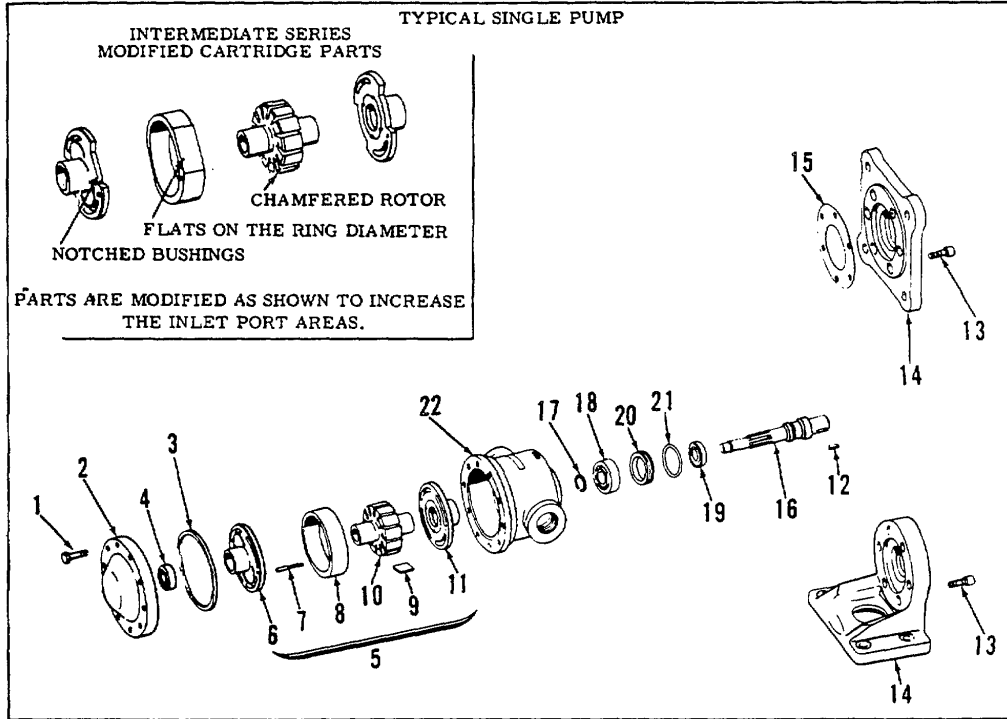

Figure 3

- | | | |
|---|---------------------------|---------------------|
| 1. HEAD SCREW | 9. VANE | 17. SNAP RING |
| 2. HEAD | 10. ROTOR | 18. SHAFT BEARING |
| 3. HEAD GASKET | 11. BUSHING | 19. SHAFT SEAL |
| 4. HEAD BEARING | 12. SHAFT KEY | 20. SPACER |
| 5. CARTRIDGE (Includes items 6 thru 11) | 13. BRACKET SCREW | 21. O RING (Spacer) |
| 6. BUSHING | 14. BRACKET (Foot/Flange) | 22. BODY |
| 7. PIN - Locating | 15. FLANGE CASKET | |
| 8. RING | 16. DRIVE SHAFT | |

REFERENCE DRAWINGS

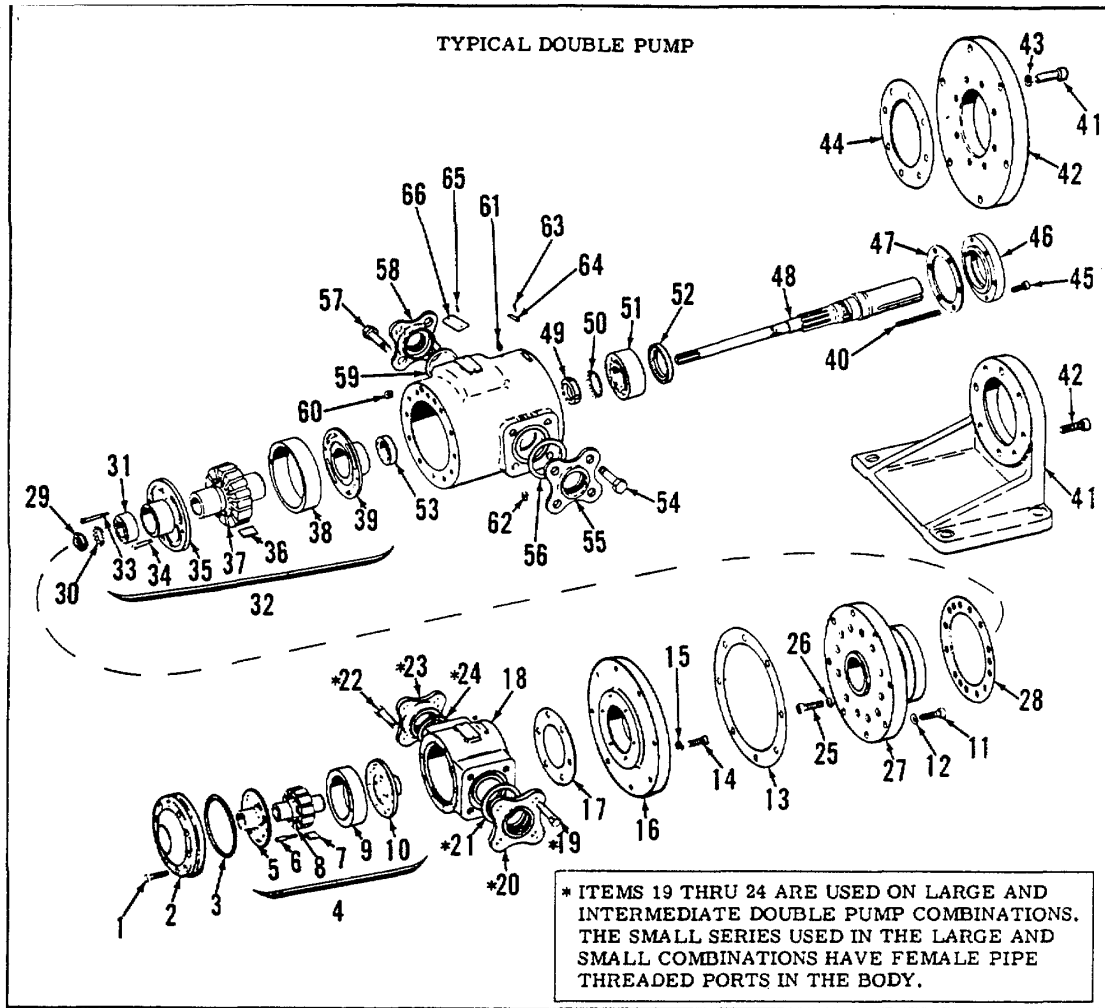
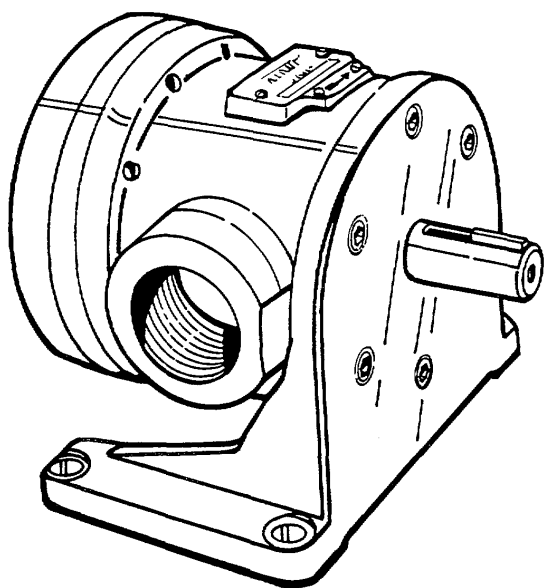

Figure 4

- | | | | |
|----------------------------|-----------------------------|--------------------|-----------------------------|
| 1. HEAD SCREW | 18 BODY | 35 BUSHING | 52 SHAFT SEAL |
| 2 HEAD | *19 FLANGE SCREW | 36 VANE | 53 SEAL |
| 3 HEAD GASKET | *20 FLANGE (Inlet) | 37 ROTOR | (Used on basic design only) |
| 4 CARTRIDGE | *21 GASKET (Inlet) | 38 RING | 54 FLANGE SCREW |
| (Includes Items 5 thru 10) | *22 FLANGE SCREW | 39 BUSHING | 55 FLANGE (Inlet) |
| 5 BUSHING | *23 FLANGE (Outlet) | 40 SHAFT KEY | 56 GASKET (Inlet) |
| 6 PIN - Locating | *24 GASKET (Outlet) | 41 BRACKET SCREW | 57 FLANGE SCREW |
| 7 VANE | 25 HEAD SCREW | 42 BRACKET | 58 FLANGE (Outlet) |
| 8 ROTOR | 26 LOCKWASHER | (Foot/Flange) | 59 GASKET (Outlet) |
| 9 RING | 27 HEAD (Intermediate) | 43 LOCKWASHER | 60 PLUG |
| 10 BUSHING | 28 GASKET | 44 FLANGE GASKET | 61 GREASE FITTING |
| 11 SCREW | 29 NUT | 45 RETAINER SCREW | (Used on basic design only) |
| 12 LOCKWASHER | 30 LOCKWASHER | 46 RETAINER | 62 GREASE RELIEF FITTING |
| 13 GASKET | 31 BEARING | 47 RETAINER GASKET | (Used on basic design only) |
| 14 SCREW | 32 CARTRIDGE | 48 DRIVE SHAFT | 63 SCREW |
| 15 LOCKWASHER | (Includes items 33 thru 39) | 49 LOCK NUT | 64 ROTATION PLATE |
| 16 MOUNTING FLANGE | 33 LOCATING SCREW | 50 LOCKWASHER | 65 SCREW |
| 17 GASKET | 34 RETAINING SCREW | 51 BEARING | 66 NAME PLATE |



**SERVICE
PARTS
INFORMATION**

**Intermediate Size
V-124, V-134, V-144 Series
Basic, -10 & -20 Designs**

-20 DESIGN

SEE SERVICE MANUAL
I-3100-S FOR
MAINTENANCE INFORMATION.

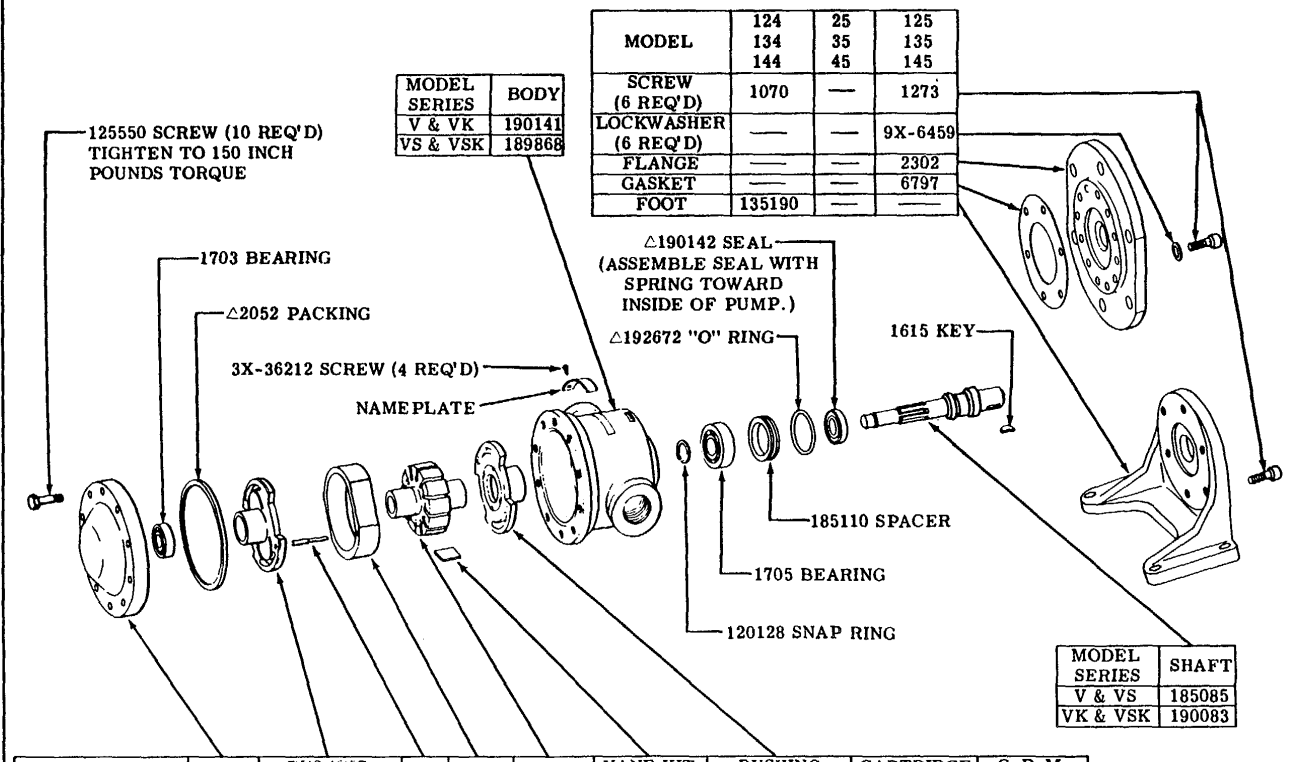

MODELS V, VK, VS & VSK	HEAD	BUSHING		PIN	RING	ROTOR	VANE KIT (12 VANES)	BUSHING		CARTRIDGE KIT	G. P. M. 1200 RPM 0 PSI
		R.H. or L.H.	R.H. or L.H.								
THESE PARTS ARE INCLUDED IN CARTRIDGE KITS											
25 - 124 - 125	18495	222046	222045	2051	24188	2042	912023	222045	222046	912077	15.4
35 - 134 - 135					2044					912078	19.5
35U - 134U - 135U					15482					912079	23.0
35X - 134X - 135X	6008				2347	2065	912024			912080	29.9
45 - 144 - 145					3246					912081	37.9

Δ INCLUDED IN
919006 GASKET
KIT.

BASIC AND -10 DESIGNS

SEE SERVICE MANUAL
I-3100-S FOR
MAINTENANCE INFORMATION.

MODEL	124, 134 144 (-10 DESIGN ONLY)	125-H 135-H 145-H	125 135 145	25 35 45
SCREW (6 REQ'D)	1070	1273	1273	—
LOCKWASHER (6 REQ'D)	—	9X-6459	9X-6459	—
FLANGE	—	27979	2302	—
GASKET	—	6797	6797	—
FOOT	135190	—	—	—

USED ON
V-124
V-134
V-144
BASIC DESIGN ONLY
— 2047
COVER
— 1228
SCREW (3 REQ'D)

* MUST BE USED WITH 125550 SCREW (10 REQ'D) (TIGHTEN TO 150 INCH POUNDS TORQUE)

FOR BASIC DESIGN MODELS, WITH COUNTERSUNK BOLT HOLES IN HEAD, USE 1072 SCREW.

MODEL	BODY
V- { 124 } { 134 } { 144 }	(BASIC DESIGN) 2040
ALL OTHER MODELS	2055

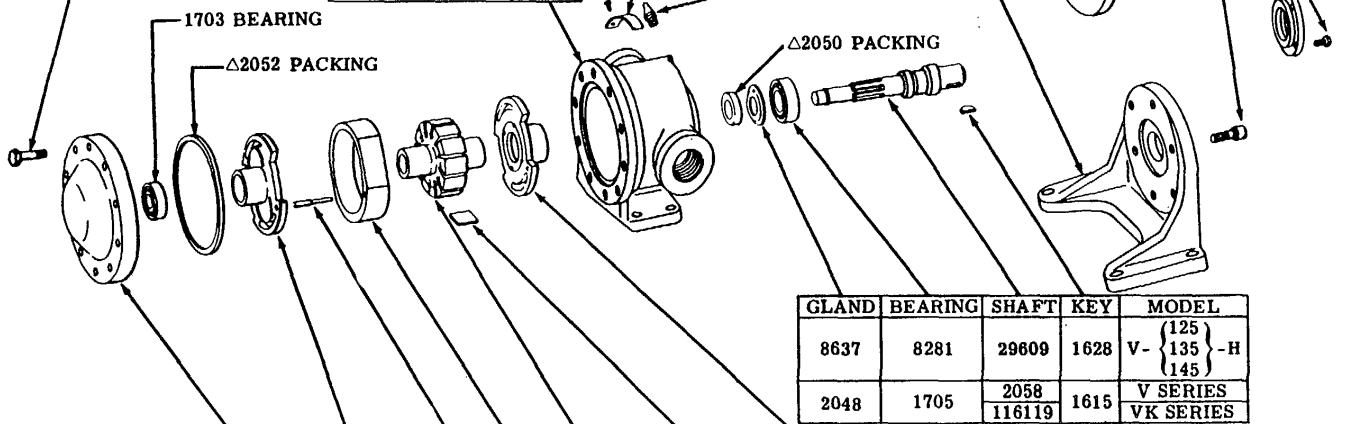

GLAND	BEARING	SHAFT	KEY	MODEL
8637	8281	29609	1628	V- { 125 } { 135 } -H { 145 }
2048	1705	2058 116119	1615	V SERIES VK SERIES

MODELS V, VK	*HEAD	BUSHING		PIN	RING	ROTOR	VANE KIT (12 VANES)	BUSHING		CARTRIDGE KIT	G. P. M. 1200 RPM 0 PSI
		R.H. or L.H.						R.H. or L.H.			
25 - 124 - 125	18495	222046	222045	2051	24188	2042	912023	222045	222046	912077	15.4
35 - 134 - 135					2044					912078	19.5
35U - 134U - 135U					15482					912079	23.0
35X - 134X - 135X					2347					912080	29.9
45 - 144 - 145	6008				3246	2065	912024			912081	37.9

△ INCLUDED IN 912035 GASKET KIT.

MODEL CODE BREAKDOWN

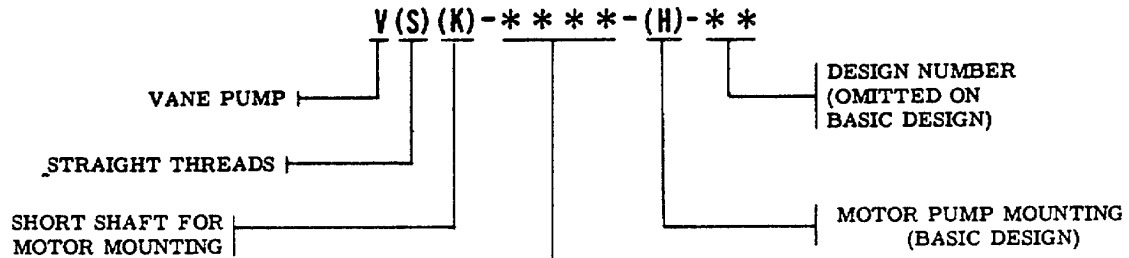

MOUNTING	AND	CAPACITY
25 - 124 - 125	-	15.4 GPM
35 - 134 - 135	-	19.5 GPM
35U - 134U - 135U	-	23.0 GPM
35X - 134X - 135X	-	29.9 GPM
45 - 144 - 145	-	37.9 GPM

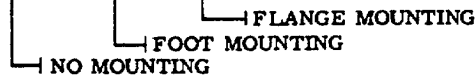

VANE AND ROTOR ASSEMBLY (SHOWN VIEWED FROM HEAD END)

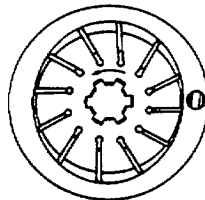

Assembly of the rotor and vanes is determined by the direction of the pump rotation. Vanes must be assembled so that the small beveled edges are trailing as shown for right hand rotation. Rotation is determined by viewing pump from shaft end.

To insure sustained efficiency and maximum trouble-free life of this precision equipment, initial and continuous filtration of the fluid medium to 25 microns or less is essential.

To insure sustained efficiency and maximum trouble-free life of this precision equipment, initial and continuous filtration of the fluid medium to 25 microns or less is essential. (For information pertaining to 10 micron filters, see installation drawing I & M 229847.)

PRINTED IN U.S.A.

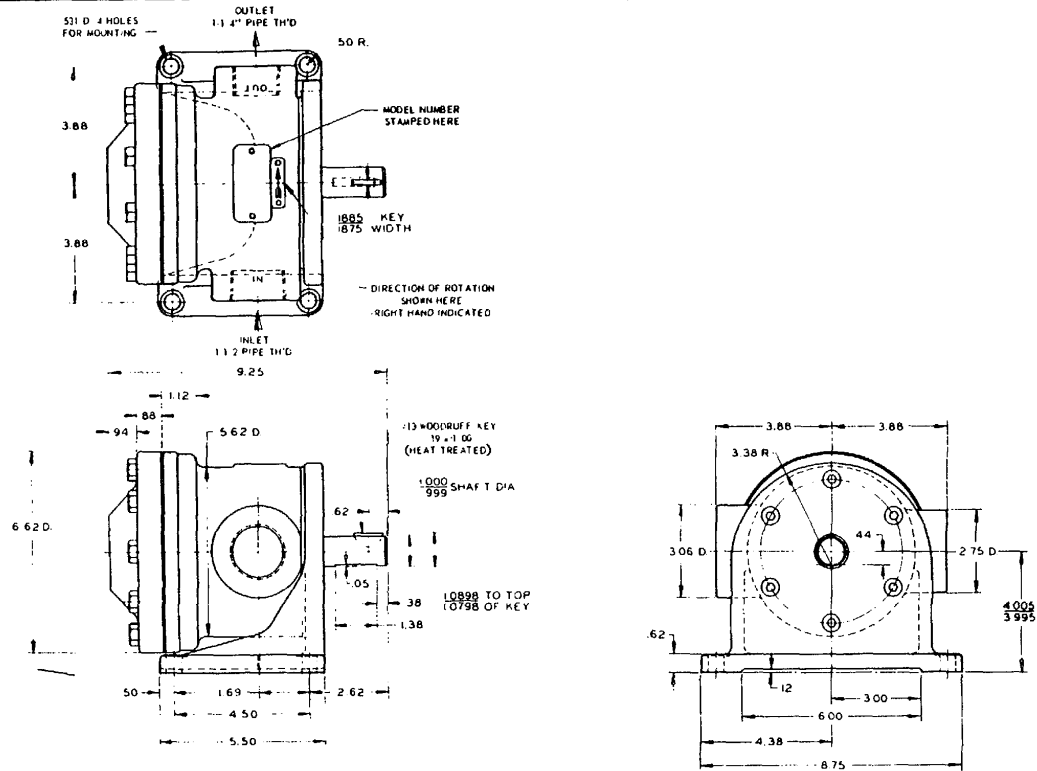

**FOOT MOUNTING
(STANDARD SHAFT)**

MODEL NUMBER		PUMP CHARACTERISTICS AT 1200 RPM BY FLUID TYPE CHARACTERISTICS AT OTHER DRIVE SPEEDS APPROXIMATELY PROPORTIONAL TO RPM DATA BASED ON PERFORMANCE AT FLUID TEMPERATURE OF 120 F VISCOSITY 150 SSU AT 100 F																					
FOOT MOUNTING	FLANGE MOUNTING	DELIVERY GPM			HP INPUT			MAX DRIVE SPEED			PUMP FLOW GPM			MAX OPERATING PRESSURE									
		0 PSI	500 PSI	1000 PSI	0 PSI	500 PSI	1000 PSI	PETROLEUM	FIRE RESISTANT	PETROLEUM	SYNTHETIC	WATER GLYCOL	CONTINUOUS		INTERMITTENT								
V 124 20	V 125 20	15.4	14.5	13.6	70	58	10.9			15.4	15.4	15.4											
V 134 20	V 135 20	19.3	18.8	18.0	75	67	12.4	1500		19.5	19.5	19.5											
V 134U 20	V 135J 20	23.0	22.2	21.3	80	81	14.9		1200	23	23	23	1800	1000	800		1200						1000
V 124X 20	V 125A 20	27.9	26.9	27.8	100	97	18.8		1200	29.9		29.9											
V 144 20	V 145 20	37.9	36.5	37.0	120	135	24.1			37.9													

INTERMITTENT DUTY IS DEFINED AS 10% OF OVERALL TIME. NO ONE APPLICATION OF PRESSURE IS TO EXCEED 10% OF ONE MINUTE (6 SECONDS).

REVISED 1864RWS

ROTATION

RIGHT HAND ROTATION VIEWED FROM DRIVESHAFT END IS STANDARD LEFT HAND ROTATION MAY BE SPECIFIED BY ADDING SUFFIX "LH" TO MODEL NUMBER
EXAMPLE V 134X 20 LH

INLET AND OUTLET PORTS REMAIN AS SHOWN REGARDLESS OF DIRECTION OF SHAFT ROTATION CHANGE OF INTERNAL ASSEMBLY, IS NECESSARY WHEN CHANGE OF DRIVESHAFT ROTATION IS REQUIRED

FLUIDS PERMISSIBLE

PETROLEUM OIL WITH A VISCOSITY RANGING BETWEEN 150 AND 225 SSU AT 100 F IS RECOMMENDED

FIRE RESISTANT FLUIDS

CAUTION SYNTHETIC AND WATER GLYCOL TYPE FIRE RESISTANT FLUIDS MAY BE USED, BUT THEY HAVE HIGH SPECIFIC GRAVITIES WHICH LIMIT THE GPM POSSIBLE THROUGH ANY ONE PUMP HOUSING EXCEEDING THIS LIMYT WILL PRODUCE CAVITATION WITH RESULTANT WEAR AND NOISE .SEE BULLETIN 59 731 DRIVE SPEED LIMITED TO 1200 RPM SELECT GPM FROM CHART ON REVERSE SIDE

SYNTHETIC FLUIDS PHOSPHATE ESTERS PHOSPHATE ESTER BASE AND CHLORINATED HYDROCARBON FLUIDS AS PRODUCED BY RESPONSIBLE SOURCES FOR RATINGS GIVEN HEREIN ARE RECOMMENDED SELECT FLUIDS WITH A VISCOSITY AS CLOSE AS POSSIBLE TO THAT FOR PETROLEUM OIL DESCRIBED ABOVE SPECIFIC GRAVITY MUST NOT EXCEED 1.42 PUMPS FOR USE WITH SYNTHETIC FLUIDS REQUIRE SEALS MADE OF DIFFERENT MATERIAL TO OBTIAN PUMPS EQUIPPED WITH SPECIAL SEALS ADD PREFIX F1 TO MODEL NUMBER FOR PHOSPHATE ESTER AND PHOSPHATE ESTER BASE FLUIDS F3 FOR CILORINATED HYDROCARBON FLUIDS

EXAMPLE F1V 134X 20

WATER GLYCOLS AS PRODUCED BY RE SPONSIBLE SOURCES, FOR RATINGS GIVEN

HERE IN. ARE RECOMMENDED SELECT FLUIDS WITH A VISCOSITY AS CLOSE AS POSSIBLE TO THAT FOR PETROLEUM OIL DESCRIBED ABOVE IT IS RECOMMENDED THAT TEMPERATURES FOR WATER GLYCOI S EE LIMITED TO A MAXIMUM OF 140 F., CONSISTENT WITH THE VISCOSITY RECOMMENDATIONS

WATER OIL EMULSIONS GENERALLY SHOULD NOT BE USED WITH THESE PUMPS TO OBTAIN SATISFACTORY SERVICE WITH EMULSIONS. USE 521 4 T YPE PUMPS SHOWN ON INSTALLATION DRAWINGS I 2366594 ANO 236695

MAXIMUM SPEED RATINGS ARE GIVEN FOR THREE TYPES OF FLUIDS SPEEDS ARE INFLUENCED BY SPECIFIC GRAVITY, VISCOSITY AND SUCTION HEAD PUMP SUCTION AND SPEED SHOULD BE RELATED SO T11AT VACUUM AT PUMP INLET DOES NOT EXCEED S" OF MERCURY FOR PETRO LEUM OIL, 3" FOR SYNTHETIC FLUID AND S" FOR WATER GLYCOL TYPE FLUIDS

FILTRATION

FOR MAXIMUM OVER ALL EFFICIENCY AND SERVICE LIFE, FILTRATION OF 25 MICRON OR LESS IS RECOMMENDED FOR FIRE RESISTANT FLUIDS THIS FILTRATION IS MANDATORY

POSITION OF INLET AND OUTLET CONNECTIONS MAY BE REVERSED BY ROTATING PUMP BODY 180 IN FOOT MOUNTING

MAXIMUM RECOMMENDED OPERATING PRESSURE

SEE CHART

MAXIMUM RECOMMENDED DRIVE SPEED (APPROX I

SEE CHART

MINIMUM RECOMWENDED DRIVE SPEED.05 RPM

WEIGHT (APPROX)

FLANGE MOUNTED MODELS 50 LBS

FOOT MOUNTED MODELS..... 52 LBS

NOTE PERFORMANCE DATA SHOWN ALSO APPLIES TO THE "VK" SERIES PUMPS AS FURNISHED ON MOTORPUMPS

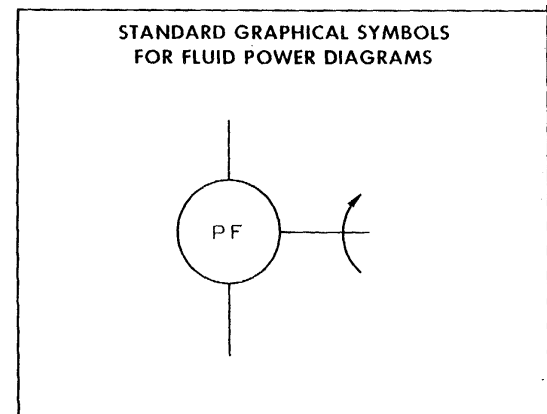
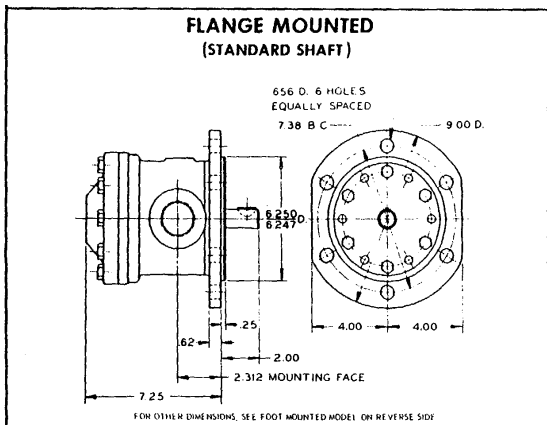

I-133744-1

FLOW CONTROL AND OVERLOAD RELIEF VALVE

On the 16". 20" and 24" special model FRG-06-24-11 has flow control and overload relief valves.

On the 24" Heavy and 28" the valve is Model FRG-06-32-11.

Maintenance information on both valves is given in bulletin 1000-SA.

Parts for both valves are shown on parts drawing I-3402-S and 514100-1.

On all the above shapers the relief valve is set to maintain a pressure of 1000 pounds per square inch. If for any reason there is indication that the pressure has dropped below this point it may be tested by attaching a hydraulic pressure gage to the opening in the valve body as shown on the illustration in section HYDRAULIC CIRCUIT. Use a gauge having at least 1500 pounds capacity.

Run the tool head carefully up against the vise or a block bolted to the table thereby stalling the ram and allowing the pressure to build up to the maximum setting of the valve. If the gauge does not register at least 1000 pounds it is probable that some obstruction is holding the relief valve open. To correct the difficulty proceed as instructed in bulletin 1000-SA.

PRESSURE BALANCING VALVE

The pressure balancing valve is Model VS-22-A.
Parts are shown on Parts Drawing Figure 12.

PRESSURE LUBRICATING VALVE

The valve for maintaining pressure for the ram lubrication is a No. 24-1/2
Vertical Check Valve.

The same valve is used on all shapers described in this book.

MAINTENANCE INFORMATION
FOR
SERIES FRG-02, FRG-03, FRG-06 & FRG-10
FLOW CONTROL & OVERLOAD RELIEF VALVES
(REFER TO DESCRIPTIVE BULLETIN 48-36 & PARTS DRAWING 925-S)

1. MODEL NUMBERS.

This maintenance information is for flow control valves with Integral Overload Relief Valve. The complete model number, which includes pressure range, volume control range and any special feature designation, is stamped on each valve and should be carefully referred to when using parts drawing or when ordering service parts.

2. FUNCTION.

The primary function of these valves is to provide accurate volume control in hydraulic circuits regardless of any variation in the imposed fluid pressure. An integral overload relief valve is also provided to limit hydraulic pressure in the system to a predetermined maximum. Both the maximum pressure and the flow control rate are adjustable. Oil from the system is discharged from the return connection of the valve to the tank whenever pressure builds up to the setting for which the valve is adjusted. That portion of the volume which is not admitted to the hydraulic circuit is also returned to the tank.

These valves may also be used for an additional purpose in the control circuit. By using the 1/4" pipe thread vent connection, which is normally plugged and a suitable venting control circuit it is possible to remotely or automatically drop the system pressure to approximately zero when desired. This venting arrangement is often used for automatically dropping pressure between working cycles of a machine. The term venting is used because of the fact that pressure on one side of the otherwise balanced control piston within the valve is dropped by connecting this chamber to tank (atmospheric pressure through small piping connections and a control valve that, when opened, allows a small volume of oil to flow or vent continuously into the tank. This, in turn, causes the relief valve to open wide and allow the entire pump delivery to discharge back to the reservoir at very low pressure until the venting circuit is closed.

3. INSTALLATION.

Complete installation and operating data is given on installation drawings R-108300 for FRG-02 Series and R-105340 for FRG-03, 06 and 10 Series. Bulletin 48-36 also contains information on installation and operation procedures. Be certain that the piping from the valve return connection discharges oil to the tank below the surface of the oil in the tank. This will do a great deal toward preventing aeration and foaming.

4. VOLUME AND PRESSURE ADJUSTMENT.

The indicating dial on the front of the valve provides a convenient means of adjusting the flow rate. Clockwise rotation increases the flow rate. Counter-clockwise rotation decreases the flow rate. The dial may be locked in any position by tightening the socket head locking screw located on the face of the dial.

Adjusting screw (95932) provides a convenient means of regulating the maximum system pressure within the range of the relief valve portion of this valve. The jam nut (707691) must be loosened before turning the pressure adjusting screw (95932). Clockwise rotation of the latter increases pressure while counter-clockwise rotation decreases pressure.

On all applications the pressure relief valve should be set for the minimum possible system operating pressure required to perform the necessary service. If it is set for excessive pressure, more power will be used than is necessary whenever the valve is being held open, as for example when a piston reaches the end of its travel and stops due to some mechanical interference.

5. CAUSES OF IMPROPER OPERATION.

Fluctuating pressure or loss of pressure at the relief valve indicates the oil has become aerated or the oil contains foreign matter. Very small chips or filings left in the tubing or piping, wiping cloth lint, core sand, or any such foreign substances can cause trouble. Every possible precaution should be taken to prevent any grit or dirt from entering the system when piping the machine and filling the tank with oil. Also precautions should be taken to protect the tank air vent opening so that the breathing action in the tank does not draw in dirt or coolant. Abrasive matter will cause pump wear and will prevent the proper operation of control valves. Dirt cannot get in if these precautions are taken.

Small air bubbles often cause a milky appearance of the oil, and this air will usually cause noisy pump and relief valve operation, as well as prevent the valve from holding a pressure steadily. Check to make certain that all system return pipes (including drain connections discharging oil to the tank) are well below the oil surface level; also, that no air leaks are present in the pump intake line (refer to pump maintenance data). Both of these conditions will cause air to be mixed with the oil. Maintain proper oil level in the tank.

6. PROCEDURE WHEN SERVICING.

The relief valve is sometimes prevented from operating correctly by lint, pipe scale or some other solid matter lodging between the pressure control piston (82800) and its seat (962491). This results in fluctuating pressure or a complete drop in pressure. Usually the condition can be remedied by starting the pump and then loosening the jam nut [170769] and backing off the adjusting screw (95932) counter-clockwise several turns. This relieves the pressure control spring (96163; and often will allow the circulating oil to clean away the dirt. The relief valve adjustment should then be turned back clockwise until the proper maximum pressure setting has been re-established. Relief valve setting may be checked by blocking machine travel or oil circulation and testing with pressure gauge.

Should it be necessary to dismantle these valves do so by driving out the two dowel pins located either side of the name plate. This procedure will release the plug, seal, spring and hydrostat valve from one side of the body and a plug, seal and sleeve from the other. To remove the throttle spool remove first the small hex socket head screw releasing the dial, then the name plate and finally the throttle. The relief valve portion of these units may be removed by turning off acorn nut, loosening the Jam nut, turning out the adjusting screw and finally tilting the body so that the remaining portions are allowed to drop out, After disassembly all parts should be thoroughly cleaned in an approved mineral oil solvent and inspected for wear. Check operation of hydrostat within the sleeve. These parts are fitted to a very close tolerance, however, the spool should have freedom of movement within the sleeve. Check the condition of the relief valve piston and its seat. Continued operation may distort the mating faces of these parts preventing proper sealing action. If this has happened, replace with new parts. At reassembly, replace all seals with new parts. All possible precautions should be taken to prevent damage to the parts and to keep them clean.

7. DIAGNOSIS OF IMPROPER OPERATION.

The following chart lists the difficulties which may possibly be experienced with the flow control valves, and indicates the probable cause and the suggested remedy. The trouble indicated in the chart may of course be due to difficulty with other equipment in the hydraulic system. Refer also to pump maintenance data.

TROUBLE	CAUSE	REMEDY
Pressure not being developed.	Relief Valve setting not high enough.	Block machine travel or oil circulation and test with pressure gage.
	Relief Valve sticking open.	Dirt under pressure adjusting ball. See Section 6 above.
	Relief Valve venting	Test venting circuit (If one is used) by blocking vent line near valve.
Noisy or erratic operation.	Aeration of oil due to low oil level or return line not discharging below oil level.	All return lines must return below oil level. See also pump service information.
External leakage around operating dial or pressure adjusting screw.	Damaged Oil Seals.	Replace oil seal. See Service Parts Drawings.

FLOW CONTROL VALVES

F(R)G-06-*11

MODEL	INNER SPRING	OUTER SPRING	VALVE	BODY S/A	SLEEVE
FG-06-*-11	271434	104998	105504	132069	307516
FRG-06-*-11	—	104998	105587	296633	105503

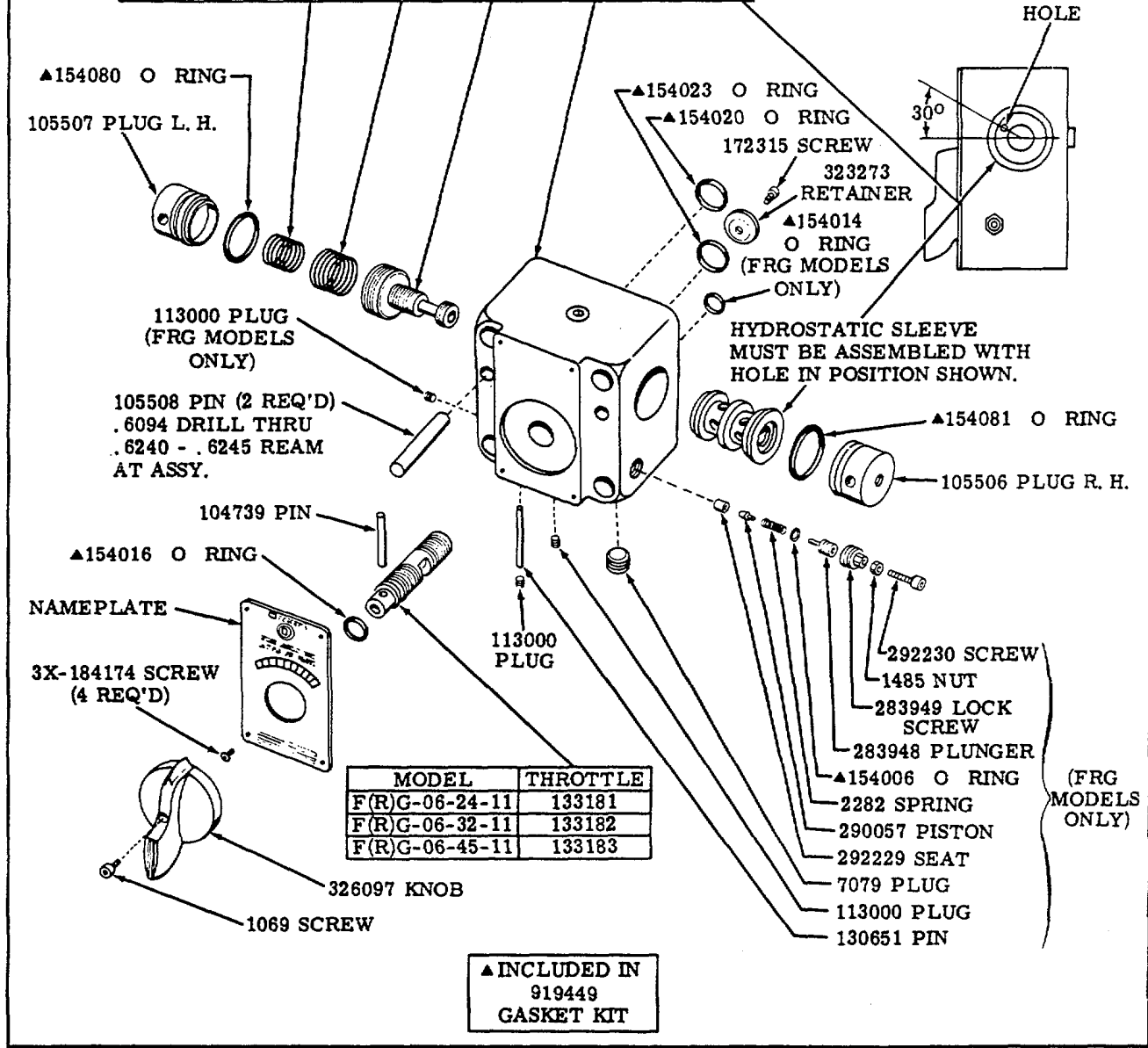

MODEL	THROTTLE
F(R)G-06-24-11	133181
F(R)G-06-32-11	133182
F(R)G-06-45-11	133183

(FRG MODELS ONLY)

F(R)G-10-*-12

MODEL	INNER SPRING	OUTER SPRING	VALVE	BODY S/A	SLEEVE
FG-10-*-12	122991	122990	104729	246429	307517
FRG-10-*-12	122991	104697	104736	292228	104728

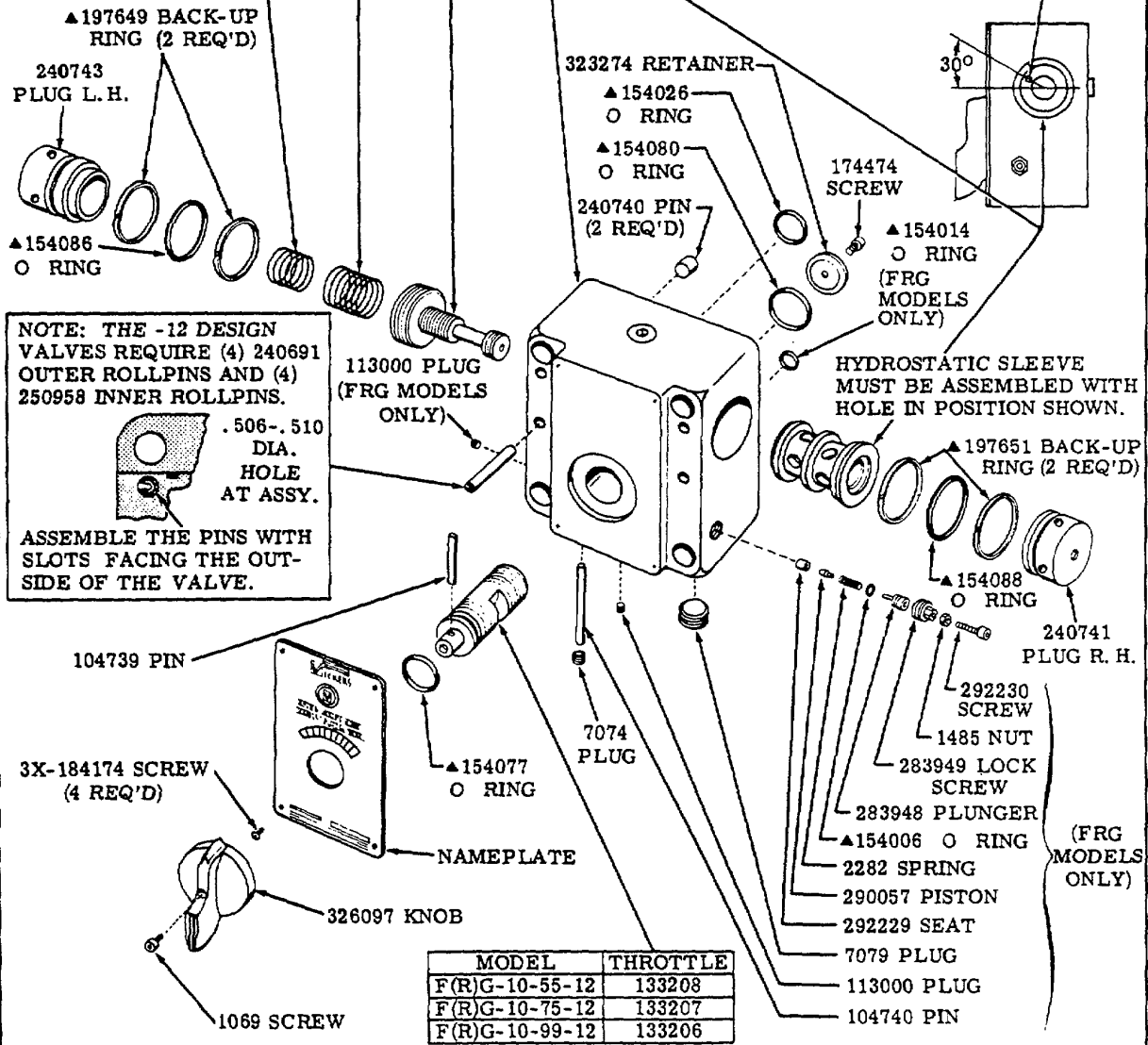

▲ INCLUDED IN
919450
GASKET KIT

FLOW CONTROL AND OVERLOAD RELIEF VALVES
SERIES FRG-06 AND FRG-10 GASKET MOUNTING

STRAIGHT THREAD CONNECTIONS

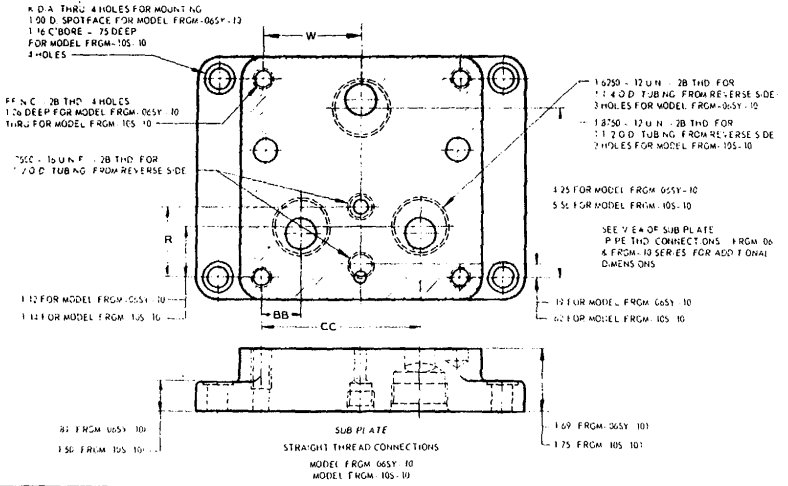
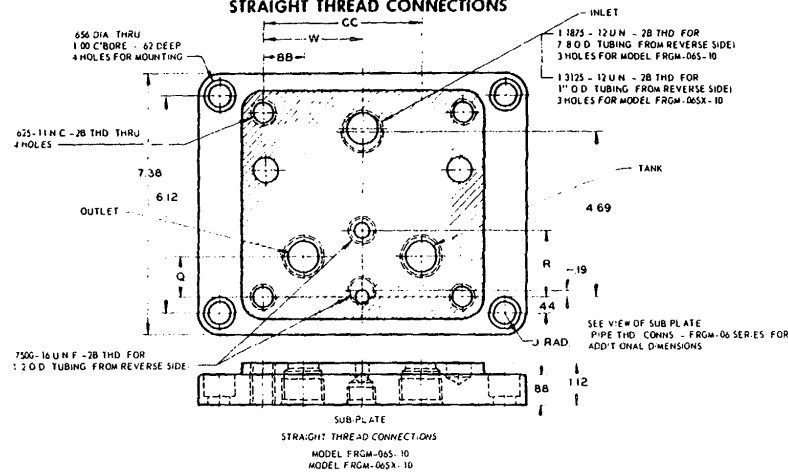

MODEL NUMBER	ADJUSTABLE METERED FLOW CAPACITY RANGE		PIPING SIZE (SUB PLATE)
	CU. IN. MIN.	G.P.M.	
FRG-06-24-11	5544	24	3/4 N.P.T. THD - 1" N.P.T. THD 7/8, 1" AND 1 1/4 O.D. TUBING
FRG-06-32-11	7392	32	
FRG-06-45-11	10395	45	
FRG-10-55-12	12705	55	1 1/4, 1 1/2 AND 2" N.P.T. THDS 1 1/2 O.D. TUBING
FRG-10-75-12	17225	75	
FRG-10-99-12	22849	99	

GENERAL DATA

THESE VALVES ARE USED AS METER IN FLOW CONTROL. THEY PERMIT THE PUMP TO OPERATE AT LOAD PRESSURE AND PROVIDES PRECISE, ADJUSTABLE CONTROL OF FLOW RATES IN HYDRAULIC CIRCUITS. SOME TYPICAL USES INCLUDE CONTROLLING THE SPEED OF WORK SPINDLES AND RATES OF TRAVEL OF TOOL HEADS OR SLIDES.

THE VALVES ARE PRESSURE COMPENSATED TO REDUCE FLOW VARIATION WITH CHANGES IN OIL PRESSURE. AN INTEGRAL, ADJUSTABLE RELIEF VALVE PROTECTS THE SYSTEM AGAINST OVERLOADS.

PUMP UNLOADING CAN BE ACCOMPLISHED BY OPENING THE VENT CONNECTION TO TANK, OR BY CLOSING THE THROTTLE - PROVIDED OIL UNDER PRESSURE IS NOT TRAPPED IN THE OUTLET PORT.

ADJUSTMENT OF FLOW RATE

ADJUST FLOW RATE BY ROTATING DIAL. FINE INCREMENTS OF ADJUSTMENT MAY BE OBTAINED WITH "VERNER" KNOB. SOCKET HEAD LOCKING SCREW MAY BE TIGHTENED TO PREVENT SELECTED SETTING FROM BEING INADVERTENTLY CHANGED.

ADJUSTMENT OF OVERLOAD RELIEF PRESSURE

ADJUST OVERLOAD RELIEF PRESSURE BY TURNING SCREW ON SIDE OF VALVE. CLOCKWISE ROTATION INCREASES PRESSURE, COUNTERCLOCKWISE ROTATION DECREASES PRESSURE. PROPER ADJUSTMENT WILL PRECLUDE EXCESSIVELY HIGH WORKING PRESSURE UPON PUMP OR OTHER EQUIPMENT.

MAXIMUM OPERATING PRESSURE RECOMMENDED 2000 P.S.I.

MINIMUM PRESSURE AT OUTLET PORT SHOULD BE 30 P.S.I. FOR CONSISTENT SATISFACTORY REGULATION OF FLOW.

METERED FLOW CAPACITY MAXIMUM

MAY BE SELECTED FROM ABOVE TABULATION OF MODELS. THIS MAXIMUM SHOULD BE NO LARGER THAN IS REQUIRED, SO THAT FINE ADJUSTMENT CAN BE MOST EASILY OBTAINED. RATED CAPACITIES ARE BASED UPON USING OIL HAVING A VISCOSITY OF 150 S.S.U. AT 100° F.

MOUNTING BOLT KITS

MOUNTING BOLT KITS ARE NOT INCLUDED WITH GASKET MOUNTED VALVES OR WITH SUB PLATES FOR THOSE VALVES. BOLTS USED SHOULD BE SAE GRADE 4 OR BETTER.

TO OBTAIN CORRECT BOLTS ORDER SEPARATELY AS FOLLOWS

- ONE 1/4" FRG-06-11 VALVE
- ONE 1/4" BK F606-646 MOUNTING BOLT KIT
- OR
- ONE 1/4" FRG-10-12 VALVE
- ONE 1/4" BK F610-647 MOUNTING BOLT KIT

STANDARD GRAPHICAL SYMBOL FOR FLUID POWER DIAGRAMS

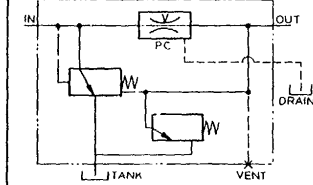

WEIGHT OF UNITS

FRG-06-11 VALVE	44 LBS
FRG-10-12 VALVE	100 LBS
FRGM-06-10 SUB PLATE	14 LBS
FRGM-06-10 SUB PLATE	21 LBS
FRGM-06S-10 SUB PLATE	18 LBS
FRGM-06SX-10 SUB PLATE	21 LBS
FRGM-06S-10 SUB PLATE	21 LBS
FRGM-10-10 SUB PLATE	52 LBS
FRGM-10X-10 SUB PLATE	52 LBS
FRGM-10Y-10 SUB PLATE	50 LBS
FRGM-10S-10 SUB PLATE	52 LBS

SPECIFICATIONS					
Hydraulic Shaper	16"	20"	24" Special	24" Heavy	28" Heavy
Stroke length—maximum.....	20"	22"	26"	26"	30"
minimum.....	1"	1"	1"	1"	1"
Table travel—horizontal.....	26"	26"	26"	30½"	30½"
vertical.....	10½"	10½"	10½"	13"	13"
Table to Ram—maximum					
Plain Table.....	14½"	14½"	14½"	17¼"	17¼"
Univ. Table Tilt Top.....	13⅞"	13⅞"	13⅞"	16½"	16½"
Univ. Table Plain Side.....	15⅞"	15⅞"	15⅞"	19¼"	19¼"
Plain Table Top—width by length...	13"x16"	13"x20"	13"x24"	14"x24"	14"x28"
Univ. Table Top—width by length...	13½"x15"	13½"x15"	13½"x15"	15"x19"	15"x19"
Tool Head—vertical hand adjustment	6¼"	6¼"	6¼"	7"	7"
Cutting speeds—feet per minute....	10 to 140	10 to 140	10 to 140	10 to 100	10 to 100
Number of cutting speed changes....	Infinite	Infinite	Infinite	Infinite	Infinite
Ram return speed, maximum FPM	150	150	150	150	150
Cross feeds to table—range.....	.002" to .110"	.002" to .110"	.002" to .110"	.002" to .110"	.002" to .110"
Vise Jaw size—(single screw).....	2½"x15"	2½"x15"	2½"x15"	3"x17"	3"x17"
Vise opens (single screw).....	14"	14"	14"	15"	15"
Tool Post Slot size.....	⅞"x1⅞"	⅞"x1⅞"	⅞"x1⅞"	1"x2"	1"x2"

MAINTENANCE

Before shipment each machine is given a serial number and is individually checked and tested by an inspector. A record of the construction and data on the tests are kept on file. Whenever reference is made to the machine, the serial number should be stated.

This number is stamped on the left front ram way of the column. Do not confuse this number with Model numbers which may be found stamped on pump or valves.

Except for regular lubrication and checking the level of the hydraulic oil the machine requires little maintenance. However, a little time spent in keeping it clean and free from dirt and chips will be well repaid by the service it will give. Clean the machine by wiping and brushing. Do not use compressed air as it only tends to force dirt and grit into the working parts.

Each piece used in the construction is carefully made and passes a rigid inspection before being built into the machine. After assembly each machine is adjusted and tested by actual cutting. It therefore merits care and consideration if it is to maintain the accuracy and long life which are built into it.

The oil in the main hydraulic system should be changed after each 2400 hours of service. After the old oil has been removed, the oil reservoir should be carefully cleaned to insure that no sludge, metal dust, nor chips remain. The procedure in refilling is then as explained in the paragraph FILLING OIL RESERVOIR.

After long service, wear will take place on sliding surfaces. To compensate for such wear gibs are provided which may be adjusted or scraped to the original working clearances.

The gib for the vertical slide of the tool head has an adjusting screw at the top and at the bottom. To adjust the gib loosen the bottom screw slightly and tighten the top one.

The gib is tapered and care must be taken to see that it is not drawn down far enough to cause it to bind. The gib holding the ram in place has capscrews to hold it down and setscrews in the side of the column to adjust it up to the ram. To adjust the gib loosen the capscrews and turn each of the setscrews inward slightly. Tighten the capscrews last and see that the gib does not bind. If the gib is too tight it will cause the ram to have a jumpy motion when running at low speeds.

The gibs for holding the cross rail against the column are flat plates and when worn, must be resurfaced and scraped to the correct fit. To hold the cross rail against sidewise motion on the column a tapered gib is placed between the rail and column on the inside edge of the left vertical way of the column. To adjust this gib loosen the jam nut on the lower side of the gib head and tighten the upper one.

LUBRICATION

The ways of the ram and column are lubricated under pressure from the main hydraulic system and should require no attention. The oil passes through a filter before going to the ways. This filter can not be cleaned and therefore should be replaced after each 1200 hours of service. The filter used is Purolator Type P-2.

The flow of oil to the ways is regulated by two needle valves placed in the lubricating lines near the filter. Both filter and needle valves are plainly visible when the square door is removed from the left side of the column.

Other points requiring lubrication are equipped with oil or grease fittings. Lubrication Chart A-HD-36 shows the locations of such fittings, the type of lubricant required, and the frequency of lubrication.

AUTOMATIC RAM LUBRICATION SUPPLIED FROM MAIN SYSTEM, PROPERLY SET AT FACTORY BY NEEDLE VALVE

FITTING	LUBRICANT	LUBRICATE
A--OIL CUP	HIGH GRADE LUB. OIL	DAILY
B--OIL HOLE	HIGH GRADE LUB. OIL	DAILY
C--ALEMITE	TEX. CHASSIS LUB "S" OR EQUAL	TWICE A WEEK
D--ALEMITE	TEX. MARFAK NO. 2 OR EQUAL	TWICE A YEAR
E--ALEMITE	TEX. MARFAK NO. 2 OR EQUAL	ONCE A WEEK

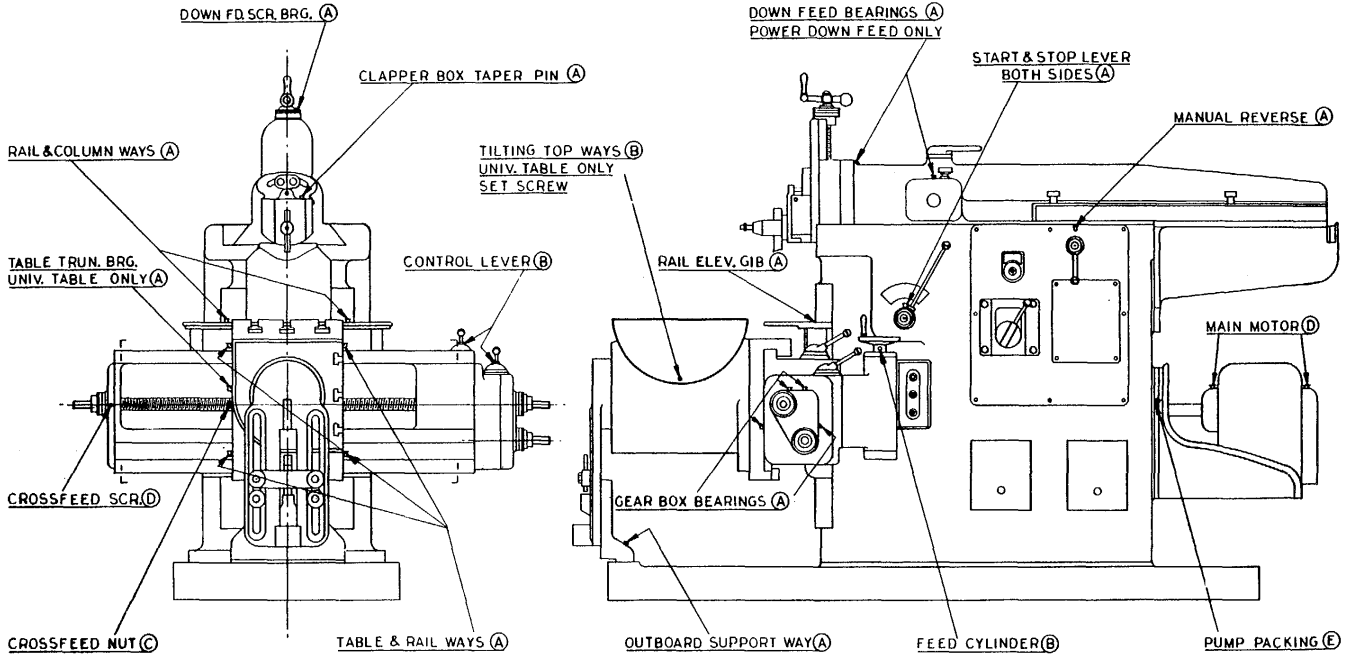

**MECHANICAL CONSTRUCTION
and PARTS LIST**

The following drawings and photographs are presented for the purpose of acquainting the operator with the construction of the machine, to assist in making adjustments and repairs, and to facilitate the ordering of repair parts whenever that occasion arises.

In many cases it will save much correspondence and down time on your machine if full information is given in the first request. Free hand sketches with the principal dimensions are very helpful.

Always refer to the machine by its serial number and give the series number of this book.

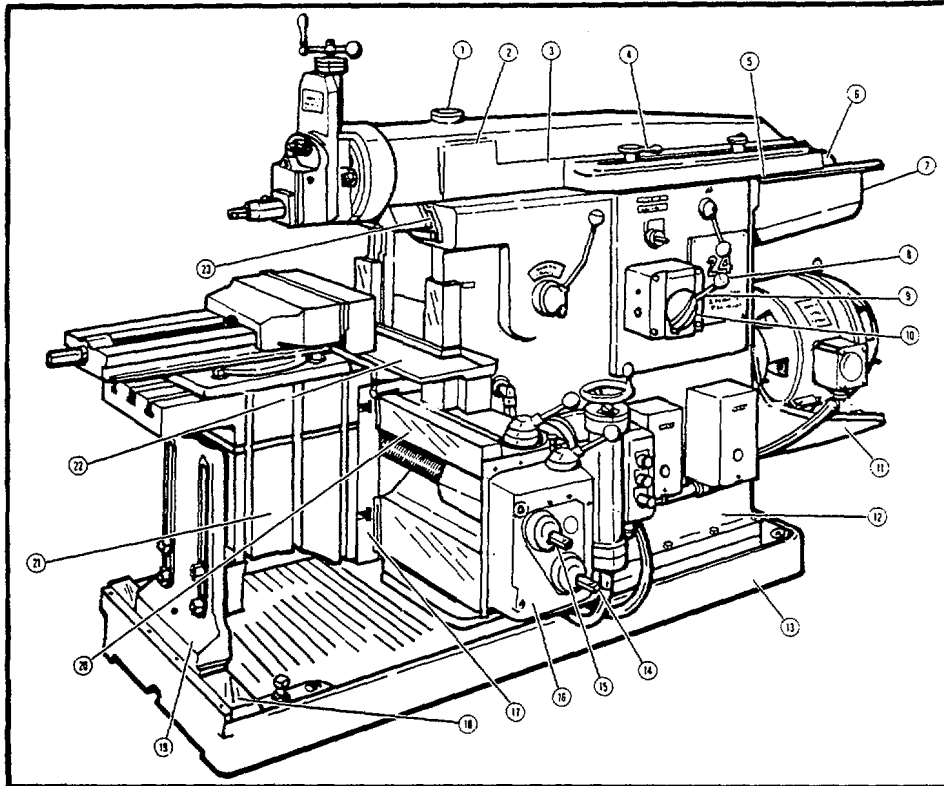

Figure 1 - Right Side with Plain Table

- 1 Ram Cover - Top
- 2 Ram Cover - Side
- 3 Ram Guard - Side
- 4 Ram
- 5 Ram Oil Wiper - Rear
- 6 Ram Guard Screen
- 7 Ram Guard
- 8 Shifter Ball
- 9 Shifter Lever
- 10 Volume Control Valve
- 11 Motor Bracket
- 12 Column
- 13 Base
- 14 Rail Elevating Shaft
- 15 Crossfeed Screw
- 16 R. H. End Plate
- 17 Apron - Plain Table
- 18 Table Support Slide
- 19 Table Support - Plain Table
- 20 Crossrail
- 21 Plain Table
- 22 Chip Guard - Plain Table
- 23 Ram Oil Wiper - Front

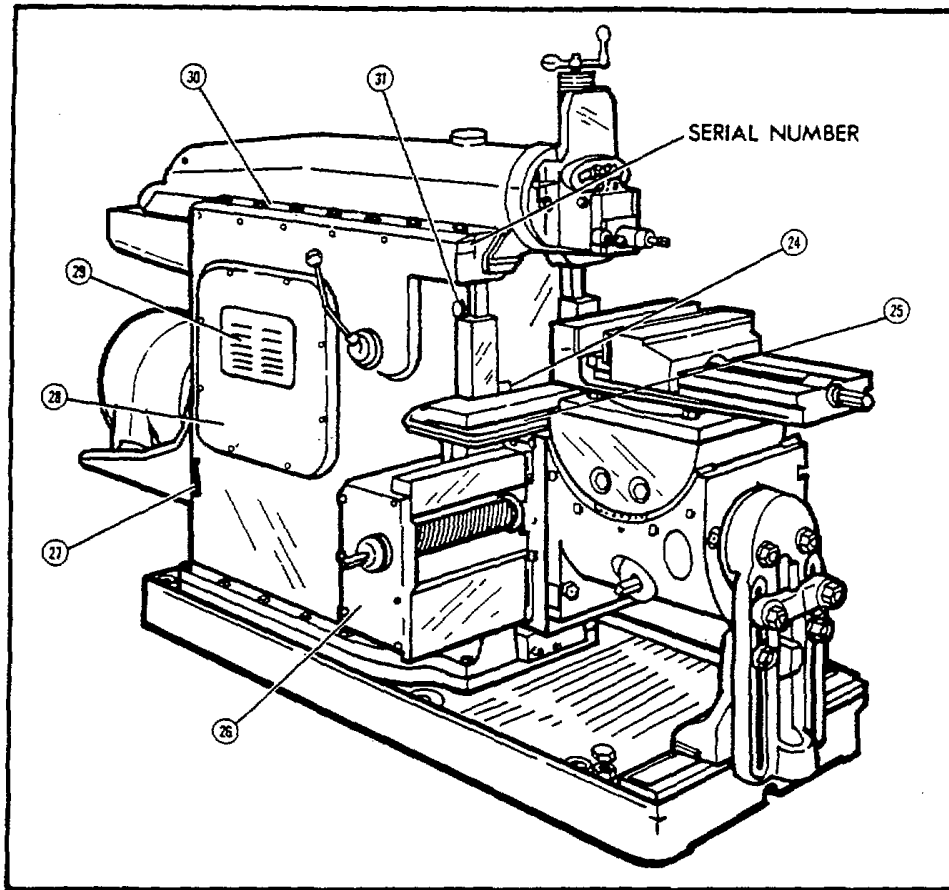

Figure 2 - Left Side with Universal Table

- 24 Rail Gib
- 25 Chip Guard - Universal Table
- 26 L. H. End Plate
- 27 Oil Gauge
- 28 Column Door
- 29 Louvre Plate
- 30 Ram Gib
- 31 Crossrail Stop

Figure 3 - Tool Head

32	Self Locking Nut
33	Downfeed Handle
34	Distance Collar
35	Graduated Collar
36	Distance Collar Spring
37	Headless setscrew
38	Downfeed Screw Bushing
39	Downfeed Slide
40	Taper Pin
41	Lock Screw Pin
42	Slide Lock-Screw
43	Lock Screw Shoe
44	Gib Adjusting Screw
45	Swivel
46	Downfeed Nut Bracket Screw
47	T-Slot Bolt
48	Washer
49	Hex. Nut
50	Gib Adjusting Screw
51	Slide Gib
52	Downfeed Screw Collar
53	Woodruff Key
54	Downfeed Screw
55	Downfeed Screw Nut
56	Downfeed Screw Nut Bracket
57	Washer
58	Socket Head capscrew
59	Clapper Box Taper Pin
60	Clapper Box
61	Hex. Nut
62	Clamp Screw Washer
63	Clapper Box Clamp Screw
64	Clapper Box Stop
65	Clapper Box Return Spring
6B	Socket Head Capscrew
67	Clapper Box Swivel Screw
68	Tool Post
69	Clapper Block
70	Tool Post Washer
71	Tool Post Screw
72	Socket Head Capscrew
73	Clapper Box Swivel Screw
74	Tool Lifter Piston
75	O Ring
76	Swivel Screw Bearing Cap
77	Clapper Box Return Spring
78	Spring Plug

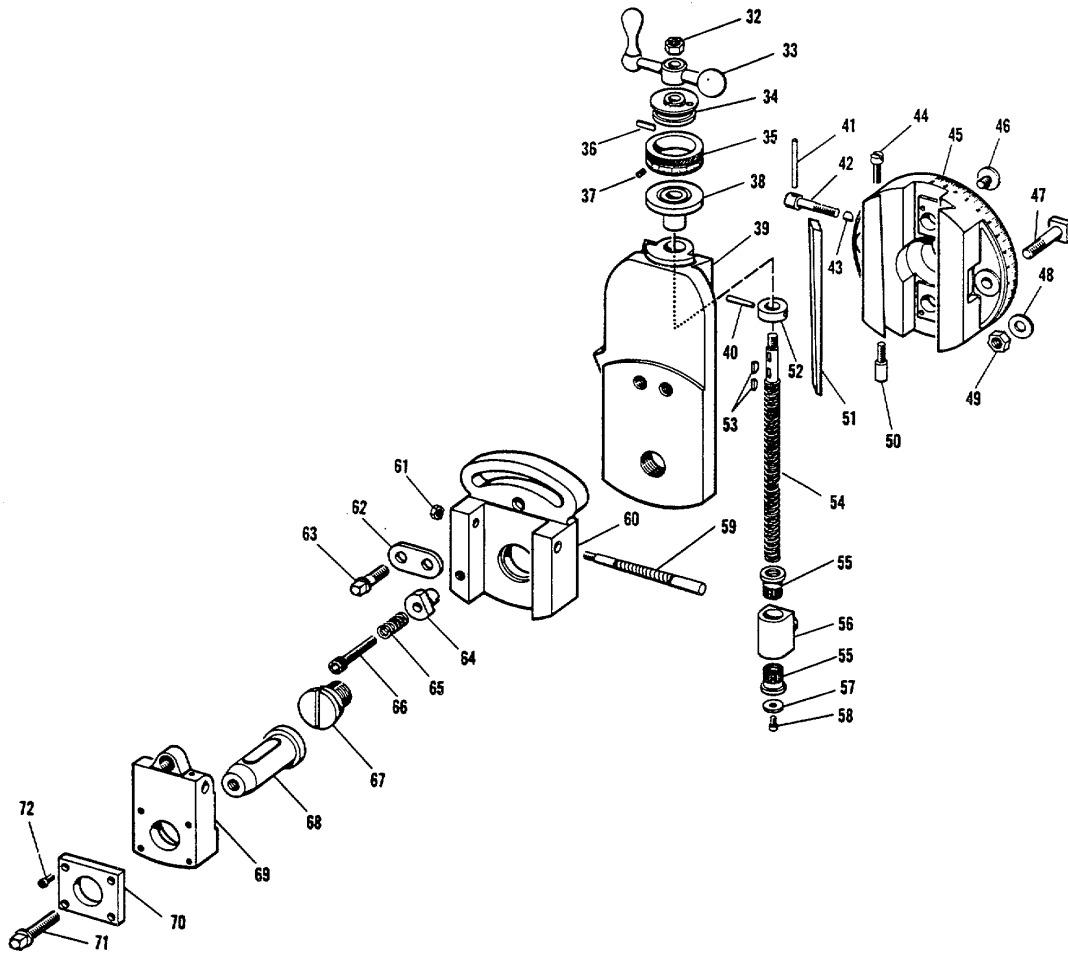
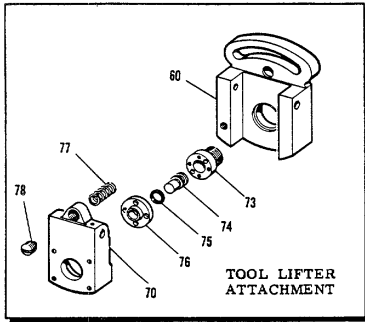

FIGURE 3 - TOOL HEAD

Figure 4 - Power Downfeed - Optional

79	Downfeed Housing Cap	114	Feed Clutch Shaft
80	Bronze Bushing	115	Bevel Gear
81	Downfeed Housing	116	Fitting Washer
82	Oil Cup	117	Socket Head Capscrew
83	Adjusting Screw Lock Nut	118	Adjusting Screw Stop
84	Adjusting Screw	L19	Taper Pin
85	Adjusting Screw Knob	120	Socket Head Setscrew
86	Taper Pin	121	Downfeed Screw Collar
87	Socket Head Capscrew	122	Woodruff Key
88	Feed Clutch Bushing	123	Power Downfeed Screw
89	Miter Gear and Clutch	124	Downfeed Bevel Gear - 14 Teeth
90	Elbow Oil Cup	125	Tit Key
91	Socket Head Capscrew	126	Downfeed Screw Miter Bearing
92	Taper Pin	127	Downfeed Bevel Gear Collar
93	Steel Ball	128	Downfeed Screw Stop
94	Socket Head Setscrew	129	Socket Head Capscrew
95	Spring	130	Socket Head Setscrew
96	Reverse Shaft Lever	131	Downfeed Nut Screw
97	Reverse Shaft Bearing	132	Dowel Pin
98	Reversing Shaft	133	Downfeed Bevel Gear - 20 Teeth
99	Feed Clutch Lever	134	Taper Pin
100	Taper Pin	135	Bevel Gear Shaft Bracket
101	Feed Lever Cam	136	Free Wheel Clutch
102	Guide Washer	137	Cam Return Clip
103	Socket Head Capscrew	138	Clutch Housing
104	Feed Lever Cam Guard	139	Socket Head Capscrew
105	Socket Head Capscrew	140	Dowel Pin
108	Dowel Pin	141	Feed Stroke Lever
107	Woodruff Key	142	Downfeed Spring
108	Bevel Gear Shaft	143	Socket Head Capscrew
109	Miter Gear Spacer	144	Oilite Bushing
110	Feed Clutch	'145	Dowel Pin
111	Shifter Shoe	146	Bearing Pin
112	Fitting Spacer	147	Washer
113	Tit Key	148	Ball Bearing
		149	Housing Cover
		150	Welch Plug
		151	Socket Head Capscrew
		152	Dowel Pin

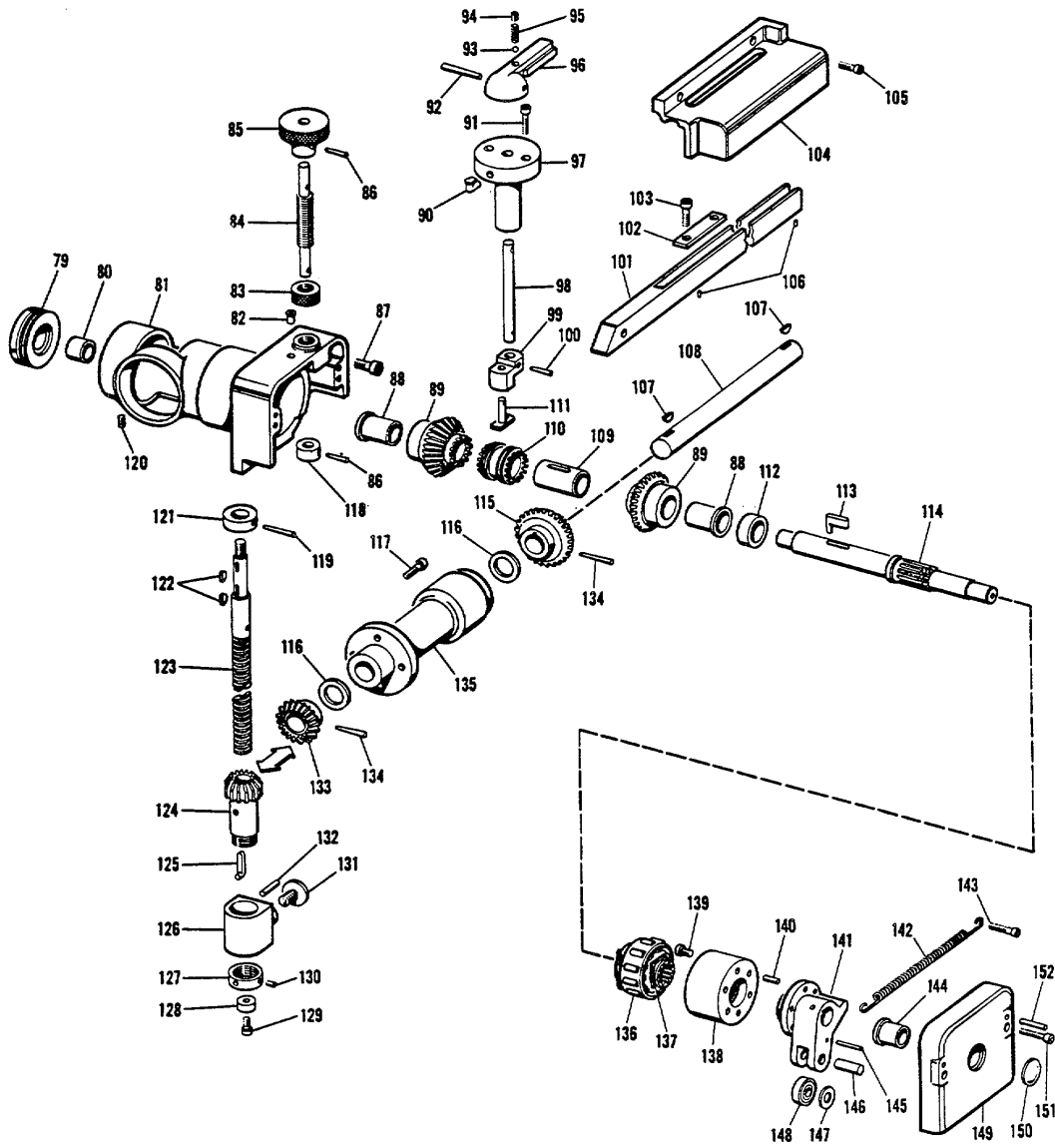

FIGURE 4 - POWER DOWNFEED - OPTIONAL

Figure 5 - Main Crossrail Unit

153	Hex. Jam Nut
154	Gib Adjusting Screw
155	Oil Cup
156	Rail Gib
157	Apron Oil Wiper (Upper)
158	Round Head Machine Screw
159	Crossrail
160	Apron Oil Wiper (Upper)
161	Rail Side Plate - LH
162	Socket Head Capscrew
163	Rail Clamp
164	Rail Stud
165	Rail Stud Washer
166	Rail Clamp Nut
167	Key
168	Crossfeed Screw Nut Bracket
169	Crossfeed Nut
170	Lock Nut
171	Socket Head Setscrew
172	Oil Seal
173	Ball Bearing
174	Right End Driven Gear
175	Lock Washer
176	Lock Nut
177	Bronze Bushing
178	Graduated Collar
179	Distance Collar Spring
180	Distance Collar
181	Socket Head setscrew
182	Headless Setscrew
183	Shifter Ball
184	Feed Clutch Shifter Lever
185	Dial Screw
186	Feed Selector Plate
187	Feed Selector Dial
188	Dowel Pin
189	Steel Ball
190	Spring
191	Socket Head Capscrew
192	Dowel Pin
193	Shifter Bearing
194	Woodruff Key
195	Shifter Shaft
196	Shifter Shoe
197	Socket Head Setscrew
198	Steel Ball
199	Spring
200	Key
201	Crossfeed Screw
202	Oil Seal
203	LH End Plate
204	Socket Head Capscrew
205	Alemite Fitting
206	Ball Bearing
207	Dowel Pin
208	Graduated Collar
209	Graduated Collar
210	Bronze Bushing
211	Right End Driven Gear
212	Right End Shaft Bushing
213	Woodruff Key
214	Right End Shaft - RH

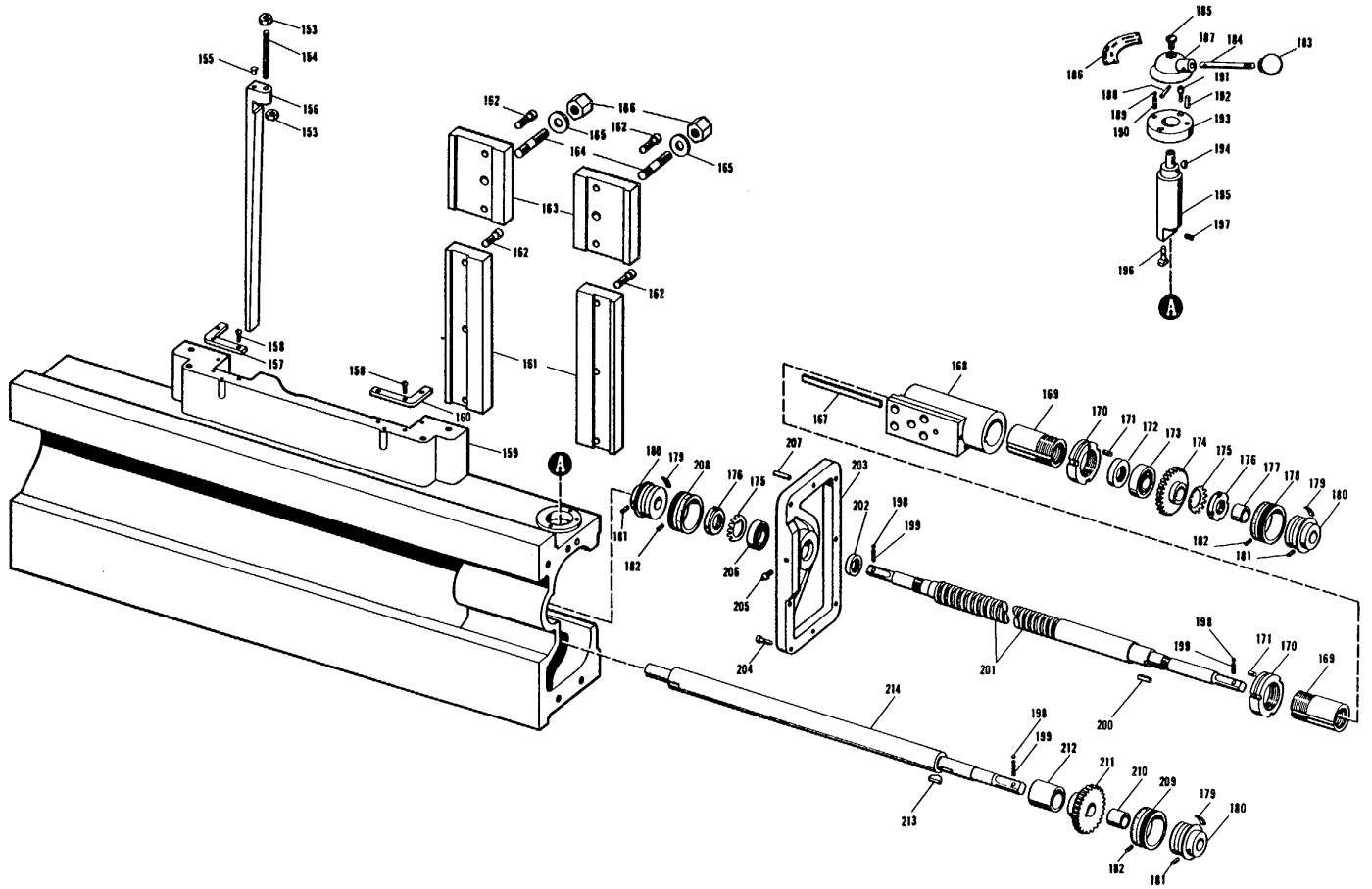

Figure 5 - MAIN CROSSRAIL UNIT

Figure 6 - Crossrail Gear Box

215	Socket Head Capscrew
216	Feed Cylinder Gasket
217	Shifter Ball
218	Feed Clutch Shifter Lever
219	Dial Screw
220	Start Lever Knob
221	Feed Directional Plate
222	Dowel Pin
223	Feed Directional Dial
224	Woodruff Key
225	Directional Shifter Shaft
226	Shifter Lever Spring
227	Shifter Lever Plunger
228	Dowel Pin
229	Welch Plug
230	Round Head Machine Screw
231	Bracket Cover
232	Elbow Oil Cup
233	Feed Cylinder Bracket
234	Socket Head Capscrew
235	R H End Plate Gasket
236	R H Bearing Retainer
237	Socket Head Capscrew
238	Bronze Bushing
239	Spline Spacing Washer
240	Tit Key
241	Reverse Bevel Shaft
242	Lock Nut
243	Lock Washer
244	Taper Pin
245	Shifter Yoke Link
246	Shifter Yoke
247	Right End Sliding Gear
248	Spline Spacing Washer
249	R H End Plate
250	Oil Cup
251	End Plate Bushing
252	Welch Plug
253	Dowel Pin
254	Socket Head Capscrew
255	Adjusting Washer
256	Miter Gear and Clutch
257	Feed Clutch Bushing
258	Sliding Feed Clutch
259	Miter Gear Spacer
260	Gear Housing End Cap
261	Welch Plug
262	Socket Head Capscrew

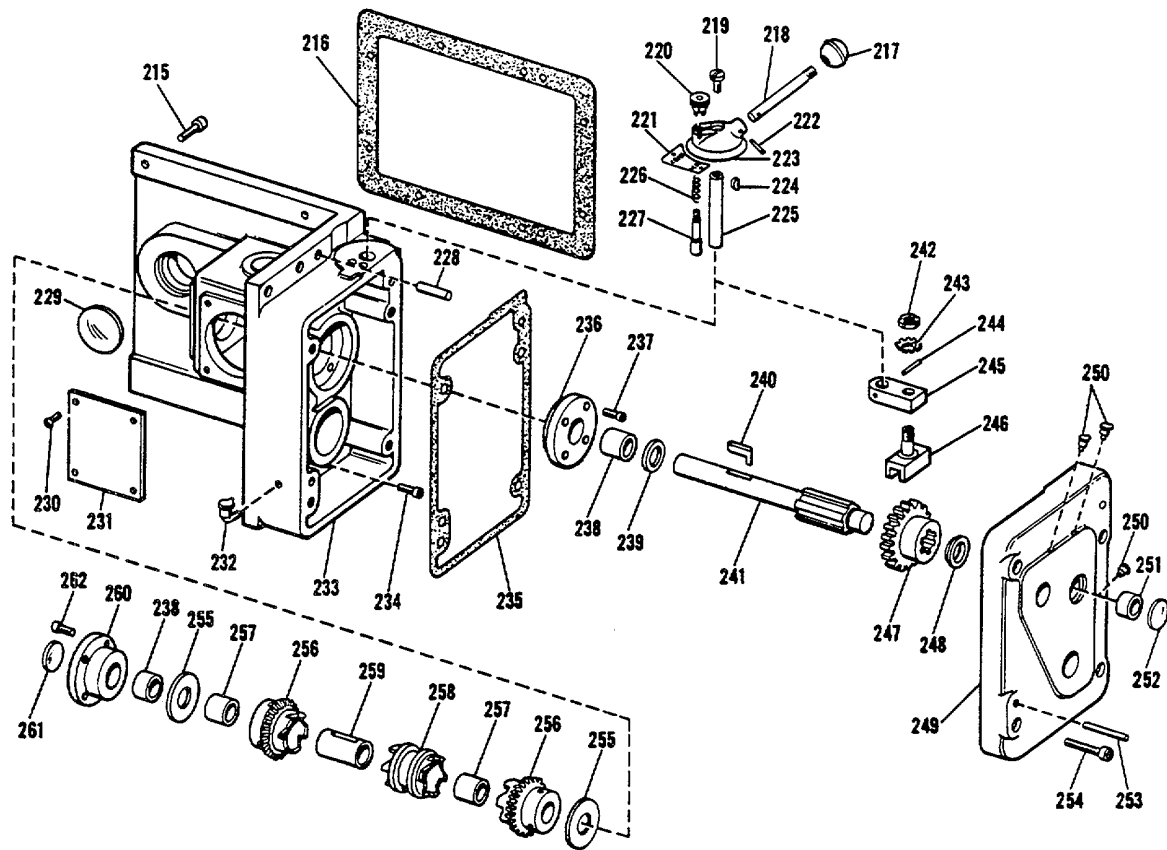

FIGURE 6 - CROSSRAIL GEAR BOX

Figure 7 Crossrail Feed and Rapid Traverse

263	Oil Seal
264	Hex. Head Capscrew
265	Motor
266	Quick Action Machine Handle
267	Handwheel
268	Hex. Jam Nut
269	Cylinder Head - Top
270	Feed Plate
271	Socket Head Capscrew
272	Woodruff Key
273	Feed Cylinder Screw
274	Stroke Adjusting Nut
275	Adjusting Nut Pin
276	Feed Cylinder Spring
277	Welch Plug
278	Feed Cylinder Plug
279	Welch Plug
280	Pipe Plug (Square Head)
281	Socket Head Capscrew
282	Dowel Pin
283	Feed Cylinder
284	Ball Bearing
285	Rapid Traverse Motor Spiral Gear
286	Welch Plug
287	Welch Plug
288	Idler Spiral Gear
289	Ball Bearing
290	Fitting Washer
291	Feed Clutch Shaft and Pinion
292	Ball Bearing
293	Socket Head Capscrew
294	Bearing Housing
295	Free Wheel Clutch
296	Key
297	Cam Return Clip
298	Clutch Race
299	Dowel Pin
300	Feed Clutch Spiral Gear
301	Socket Head Setscrew
302	Fibre Washer
303	Friction Disc
304	Spring
305	Ball Bearing
306	Needle Bearing
307	Feed Miter Gear
308	Key
309	Feed Piston
310	Cup Packing
311	Packing Retainer
312	Socket Head Capscrew
313	Feed Cylinder Cover Gasket
314	Cylinder Head - Bottom
315	Socket Head Capscrew

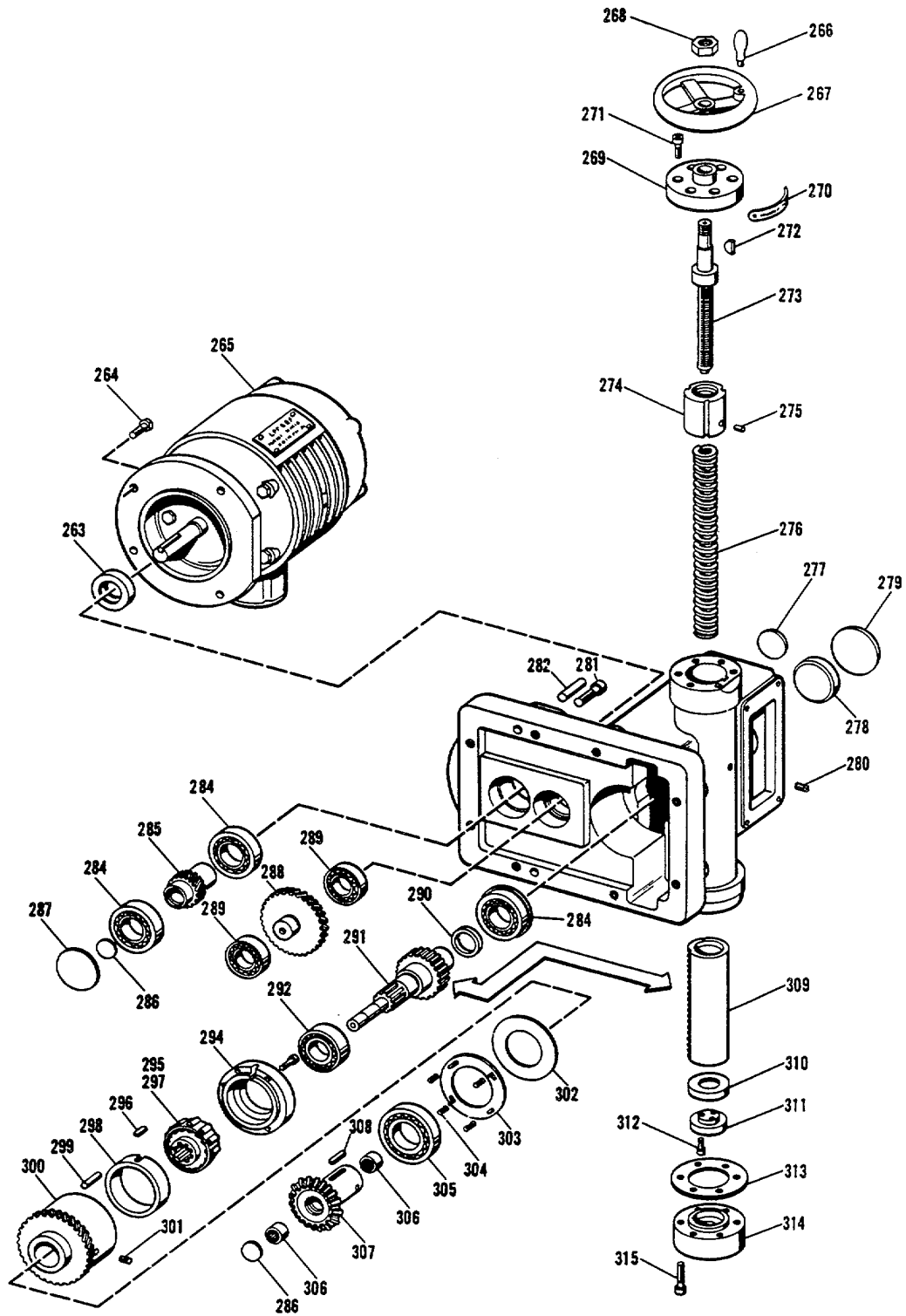

FIGURE 7 - CROSSRAIL FEED AND RAPID TRAVERSE

Figure 8 - Crossrail Vertical Feed

316	Welch Plug
317	Elevating Nut Bracket Cover
318	Socket Head Capscrew
319	Dowel Pin
320	Socket Head Capscrew
321	Dowel Pin
322	Thrust Bearing
323	Worm Wheel and Nut
324	Welch Plug
325	Oil Seal
326	Ball Bearing
327	Bearing Spacer
328	Rail Elevating Worm
329	Key
330	Elevating Nut Bracket
331	Ball Bearing
332	Thrust Bearing Cap
333	Socket Head Capscrew
334	Oil Seal
335	Roller Bearing
336	Oil Seal
337	Bearing Cap Washer
338	Nut Bearing Cap
339	Socket Head Capscrew
340	Rail Elevating Screw
341	Key
342	Elevating Screw Bracket
343	Leveling Jack
344	Socket Head Capscrew

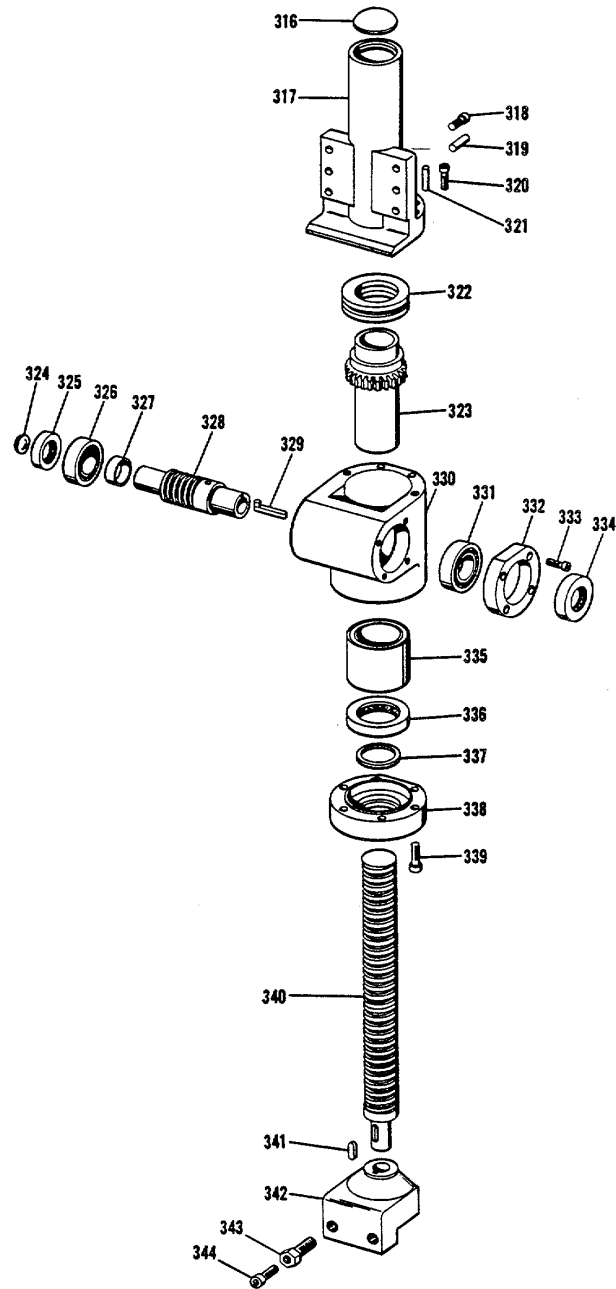

FIGURE 8 - CROSSRAIL VERTICAL FEED

Figure 9 - Universal Table - Optional

345	Worm Shaft
346	Woodruff Key
347	Worm Thrust Nut
348	Tilting Top
349	Clamp Shoe
350	Oil Wiper
351	Round Head Machine Screw
352	Graduated Plate
353	Worm Thrust Washer
354	Thrust Bearing
355	Bronze Bushing
356	Thrust Bushing
357	Reverse Table Worm
358	Socket Head Set Screw
359	Worm Adjusting Nut
360	Bronze Bushing
361	Escutcheon Pin
362	Bearing Cartridge
363	Spacer
364	Tilting Top Worm
365	Bronze Bushing
366	Worm Shaft
367	Woodruff Key
368	Lock Nut
369	Lock Washer
370	Thrust Bearing
371	Graduated Dial
372	Table Support
373	Table Support Clamp Stud
374	Washer
375	Hex. Nut
376	Table Lever Screw
377	Table Lever Bracket
378	Dowel Pin
379	Washer
380	Table Support Stud
381	T-Slot Bolt
382	Socket Head Capscrew
383	Table Locating Plug
384	Table Support Bracket
385	Oil Wiper - Table Support
386	Round Head Machine Screw
387	Table Support Slide
388	Socket Head Capscrew
389	Oil Wiper
390	Alemite Fitting
391	Dowel Pin
392	Socket Head Capscrew
393	Oil Wiper - LH
394	Apron
395	Revolving Table
396	Lock Block
397	Socket Head Capscrew
398	Clamp Stud - Tilting Top
399	Apron Gib Support
400	Table Clamp
401	Hex. Head Capscrew
402	Gib Adjusting Screw
403	Socket Head Capscrew
404	Apron Gib
405	Elbow Oil Cup
406	Oil Wiper - RH

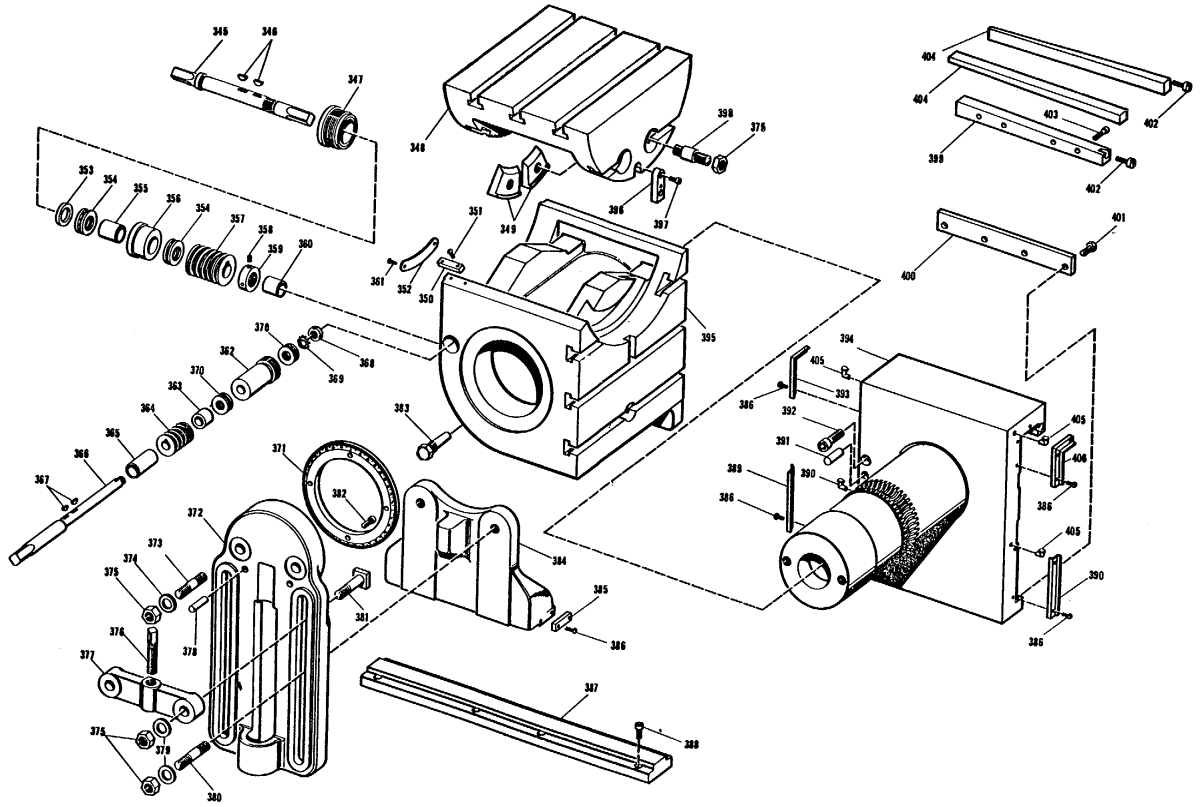

FIGURE 9 -- UNIVERSAL TABLE - OPTIONAL

Figure 10 - Pilot Valve and Trip Dogs

407	Woodruff Key
408	Manual Reverse Pin
409	Pilot Valve Shaft
410	Manual Reverse Fork
411	Manual Reverse Shaft
412	Detent Spring
413	Steel Ball
414	Dial Screw
415	Socket Head Setscrew
416	Woodruff Key
417	Manual Reverse Dial
418	Shifter Lever
419	Shifter Ball
420	Socket Head Capscrew
421	Dowel Pin
422	Pilot Valve Shoe
423	Pilot Valve Cover
424	Pilot Valve Cap Gasket
425	Pilot Valve Spool
426	Pilot Valve Sleeve
427	Oil Seal
428	1/8" Pipe Plug
429	Dowel Pin
430	O Ring
431	Dowel Pin
432	Pilot Valve Body
433	Pilot Valve Cover
434	Socket Head Capscrew
435	Reverse Cam - LH
436	Woodruff Key
437	Cam Clamp Screw
438	Dowel Pin
439	Pilot Valve Bracket
440	Taper Pin
441	Trip Handle
442	Reverse Cam - RH
443	Pilot Valve Dog - LH
444	Ram Control Bracket
445	Pilot Valve Dog - RH
446	Clamp Knob Washer
447	Socket Head Capscrew
448	Machine Handle
449	Clamp Knob Washer
450	Cam Clamp Knob
451	Washer
452	Socket Head Capscrew
453	Cam Clamp Knob

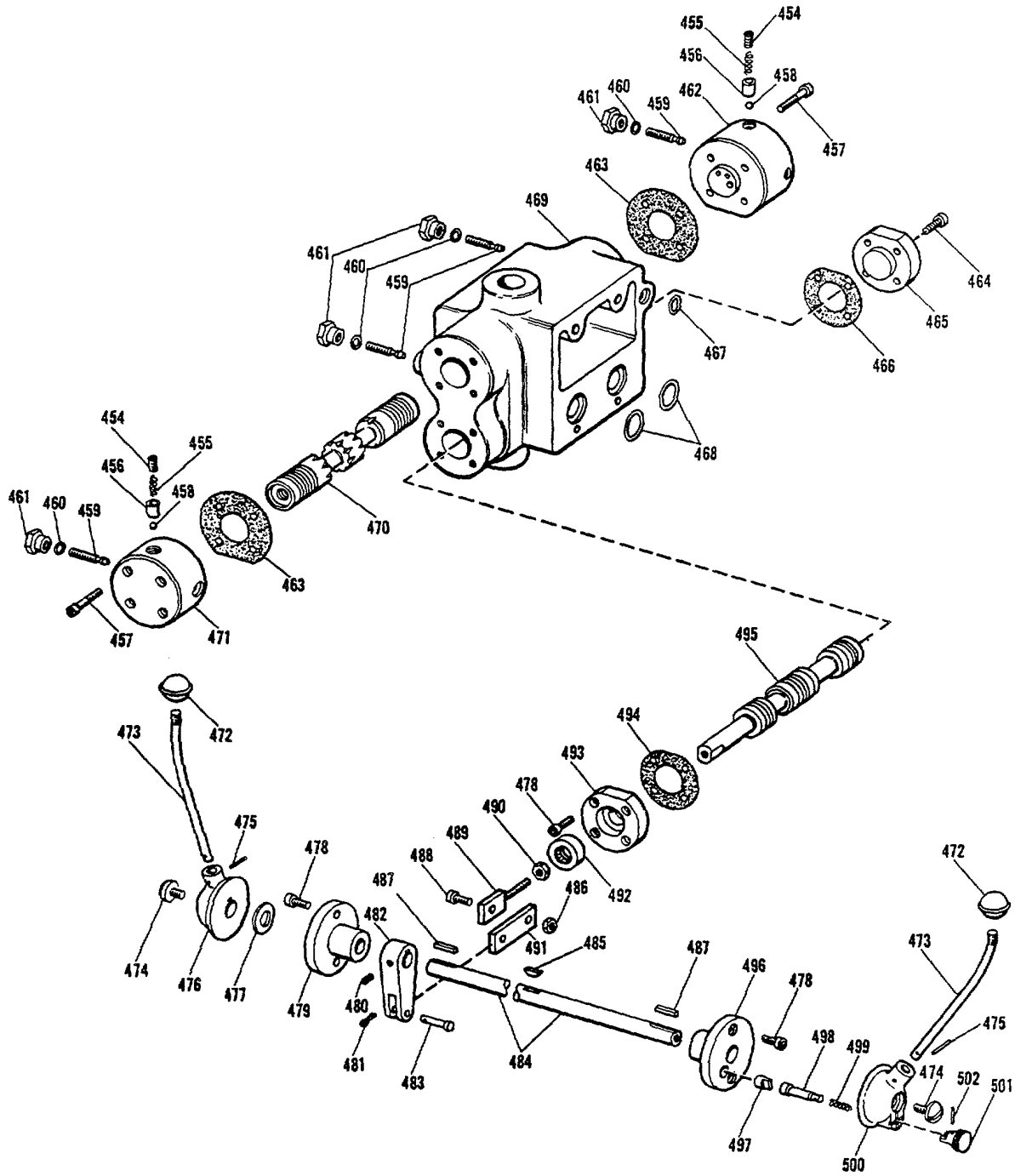

FIGURE 10- PILOT VALVE AND TRIP DOGS

Figure 11 - Combination Valve and Controls

454	3/8" Pipe Plug
455	Check Valve Spring
456	Ball Retainer
457	Socket Head Capscrev
458	Steel Ball
459	Needle Valve
460	O Ring
461	Needle Valve Nut
462	4-Way Cap - Rear
483	Valve Cap Gasket
464	Socket Head Capscrev
465	Stop Valve Cap - Rear
466	Valve Cap Gasket
467	O Ring
468	O Ring
469	Combination Valve Body
470	4-Way Valve Spool
471	4-Way Cap - Front
472	Shifter Ball
473	Start and Stop Lever
474	Dial Screw
475	Dowel Pin
476	Start Lever Dial - LH
477	Dished Washer
478	Socket Head Capscrew
479	Shaft Bearing - LH
480	Socket Head Setscrew
481	Cotter Pin
482	Valve Shifter Fork
483	Link Pin
484	Start Lever Shaft
485	Woodruff Key
486	Hex. Jam Nut
487	Key
488	Shoulder Screw
489	Lever Pivot
490	Hex. Nut - Jam
491	Lever Link
492	Oil Seal
493	Stop Valve Cap - Front
494	Valve Cap Gasket
495	Stop Valve Spool
496	Shaft Bearing - RH
497	Stop Pin
498	Start Lever Plunger
499	Dial Spring
500	Start Lever Dial - RH
501	Start Lever Knob
502	Dowel Pin

Figure 12 - Hydraulic Valves

503	Hex. Jam Nut
504	Standard Copper Washer
505	Socket Head Setscrew
506	Valve Spring Cap
507	Copper Washer
508	Spring Guide
509	Valve Spring
510	Valve Spool
511	1/8" Pipe Plug
512	Valve Body
513	Valve Cap
514	Socket Head Capscrew
515	Valve End Cap
516	Valve End Cap Gasket
517	Valve Spring
518	Valve Spool
519	Valve Body
520	Vickerseal
521	Plunger
522	Valve End Cap
523	Socket Head Capscrew
524	Valve Cap
525	Dowel Pin
526	Valve Cap Gasket
527	Valve Body
528	Valve Spool
529	Woodruff Key
530	Valve Cover
531	Socket Head Machine Screw
532	Oil Seal
533	Socket Head Setscrew
534	Valve Dial
535	Acorn Nut
536	Socket Head Capscrew
537	Valve Spring Cap
538	Valve Spool
539	Valve Body
540	O Ring
541	O Ring
542	O Ring
543	Valve Cap

SEQUENCE
VALVE
VS-22A

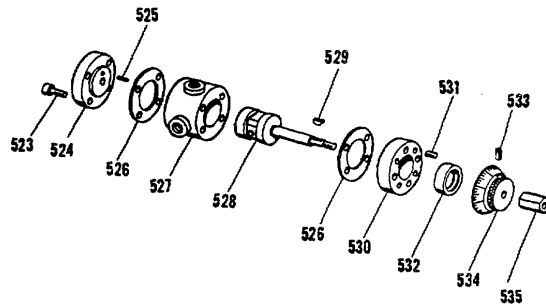
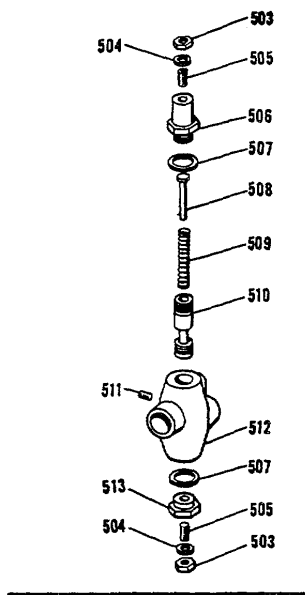

HIGH RETURN
SELECTOR VALVE
VS-23A

SEQUENCE
VALVE
VS-20A

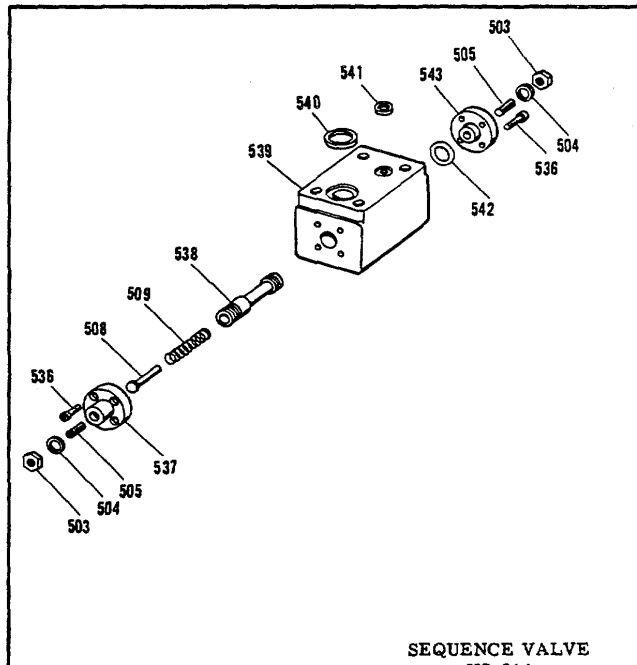
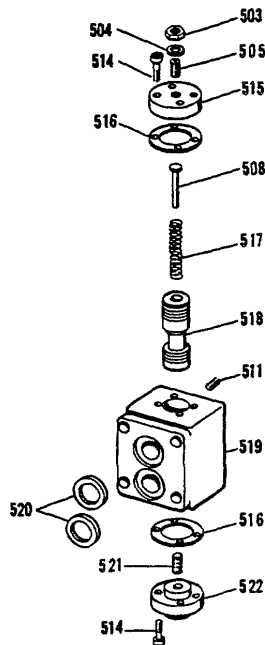

SEQUENCE VALVE
VS-21A

FIGURE 12- HYDRAULIC VALVES

Figure 13 - Ram Cylinder

544	Hex. Nut (Castellated)
545	Shakeproof Washer
546	Oil Seal
547	Socket Head Capscrew
548	Cylinder Head - Front
549	Vee Seals
550	Packing Gland
551	O Ring Gasket
552	Ram Cylinder Body
553	Socket Head Capscrew
554	Cylinder Head - Rear
555	Hex. Nut
556	Piston Ring - Step Seal
557	Piston Head
558	Piston Rod

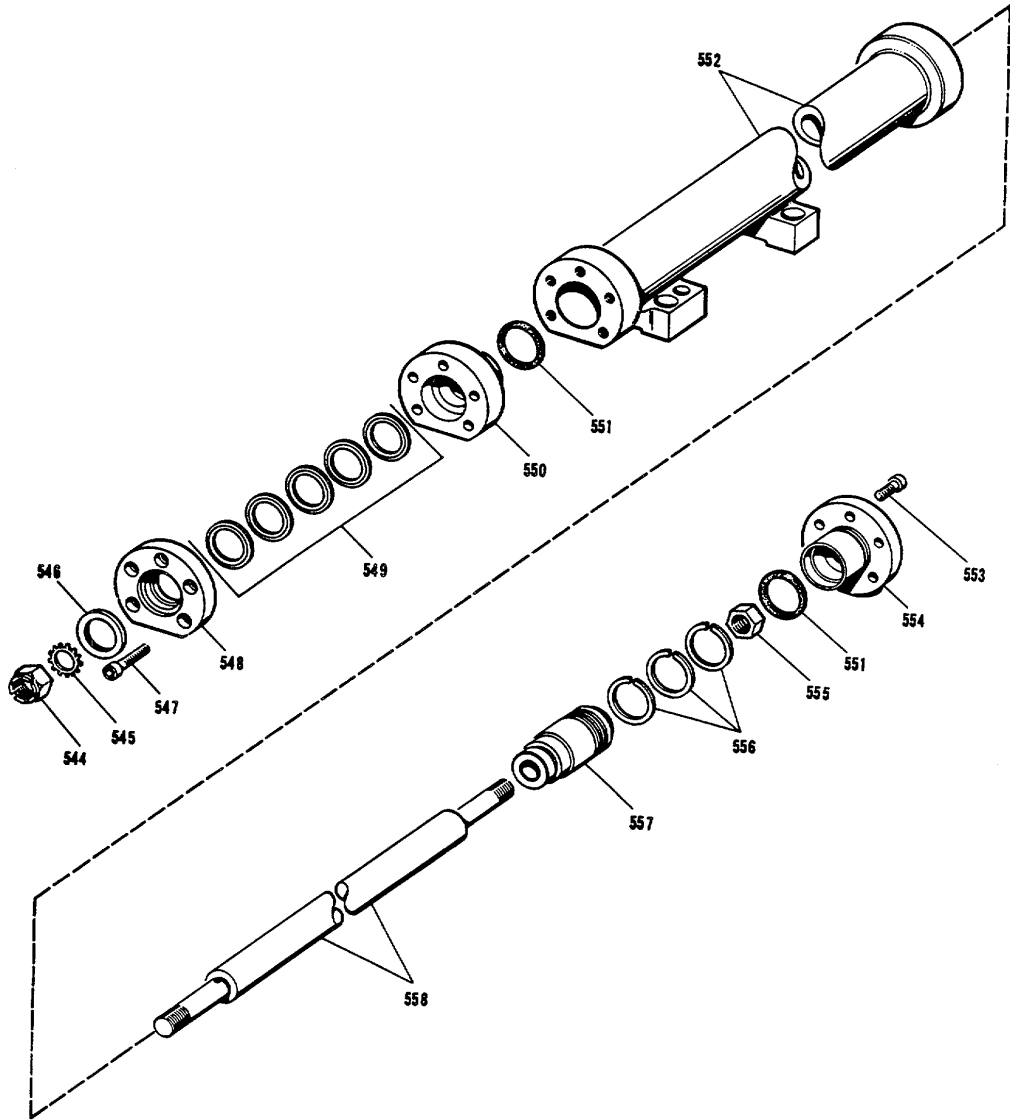

FIGURE 13- RAM CYLINDER

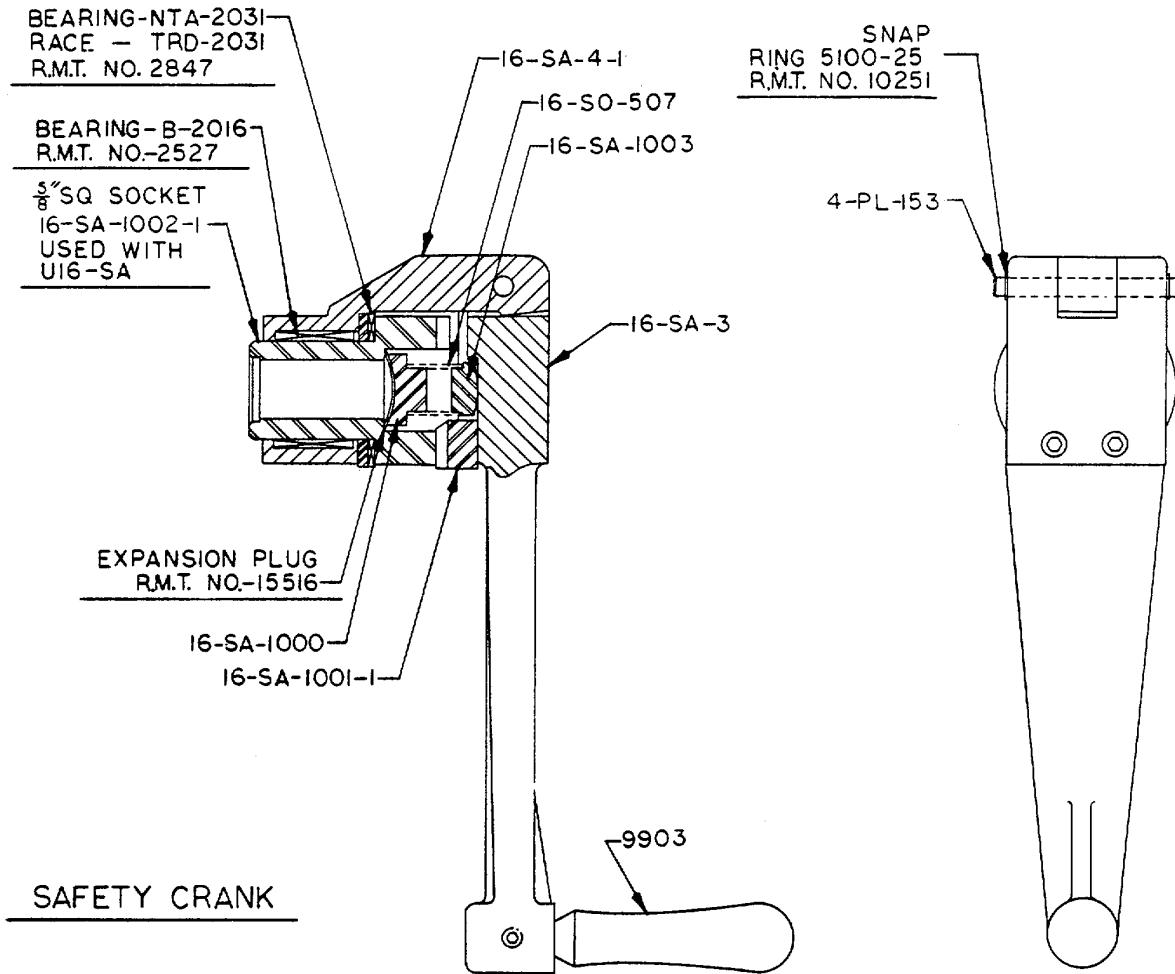

FIGURE 14 - SAFETY CRANK

65 (66 blank)

By Order of the Secretary of the Army:

E. C. MEYER
General, United States Army
Chief of Staff

Official:

ROBERT M. JOYCE
Brigadier General, United States Army
The Adjutant General

Distribution:

To be distributed in accordance with Special List.

U.S. GOVERNMENT PRINTING OFFICE 1982 O - 385-134

U.S. ARMY GENERAL PUBLICATIONS CENTER, ST. LOUIS, MO, 1985

RECOMMENDED CHANGES TO EQUIPMENT TECHNICAL PUBLICATIONS



THEN... JOT DOWN THE DOPE ABOUT IT ON THIS FORM. CAREFULLY TEAR IT OUT. FOLD IT AND DROP IT IN THE MAIL!

SOMETHING WRONG WITH THIS PUBLICATION?

FROM: (PRINT YOUR UNIT'S COMPLETE ADDRESS)

DATE SENT

PUBLICATION NUMBER

PUBLICATION DATE

PUBLICATION TITLE

BE EXACT... PIN-POINT WHERE IT IS

PAGE NO.	PARA-GRAPH	FIGURE NO.	TABLE NO.

IN THIS SPACE TELL WHAT IS WRONG AND WHAT SHOULD BE DONE ABOUT IT:

TEAR ALONG PERFORATED LINE

PRINTED NAME, GRADE OR TITLE, AND TELEPHONE NUMBER

SIGN HERE:

DA FORM 2028-2
1 JUL 79

PREVIOUS EDITIONS ARE OBSOLETE.

P.S.—IF YOUR OUTFIT WANTS TO KNOW ABOUT YOUR RECOMMENDATION MAKE A CARBON COPY OF THIS AND GIVE IT TO YOUR HEADQUARTERS.

PIN: 049334-000